

## MM74C925, MM74C926, MM74C927, MM74C928 4-Digit Counters with Multiplexed 7-Segment Output Drivers

### General Description

These CMOS counters consist of a 4-digit counter, an internal output latch, NPN output sourcing drivers for a 7-segment display, and an internal multiplexing circuitry with four multiplexing outputs. The multiplexing circuit has its own free-running oscillator, and requires no external clock. The counters advance on negative edge of clock. A high signal on the Reset input will reset the counter to zero, and reset will the carry-out low. A low signal on the Latch Enable input will latch the number in the counters into the internal output latches. A high signal on Display Select input will select the number in the counter to be displayed; a low level signal on the Display Select will select the number in the output latch to be displayed.

The MM74C925 is a 4-decade counter and has Latch Enable, Clock and Reset inputs.

The MM74C926 is like the MM74C925 except that it has a display select and a carry-out used for cascading counters. The carry-out signal goes high at 6000, goes back low at 0000.

The MM74C927 is like the MM74C926 except the second most significant digit divides by 6 rather than 10. Thus, if the clock input frequency is 10 Hz, the display would read tenths of seconds and minutes (i.e., 9:59.9).

The MM74C928 is like the MM74C926 except the most significant digit divides by 2 rather than 10 and the carry-out is

an overflow indicator which is high at 2000, and it goes back low only when the counter is reset. Thus, this is a 3½-digit counter.

### Features

- Wide supply voltage range 3V to 6V
- Guaranteed noise margin 1V
- High noise immunity 0.45 V<sub>CC</sub> (typ.)
- High segment sourcing current 40 mA @ V<sub>CC</sub> = 1.6V, V<sub>CC</sub> = 5V
- Internal multiplexing circuitry

### Design Considerations

Segment resistors are desirable to minimize power dissipation and chip heating. The DS75492 serves as a good digit driver when it is desired to drive bright displays. When using this driver with a 5V supply at room temperature, the display can be driven without segment resistors to full illumination. The user must use caution in this mode however, to prevent overheating of the device by using too high a supply voltage or by operating at high ambient temperatures.

The input protection circuitry consists of a series resistor, and a diode to ground. Thus input signals exceeding V<sub>CC</sub> will not be clamped. This input signal should not be allowed to exceed 15V.

### Connection Diagrams

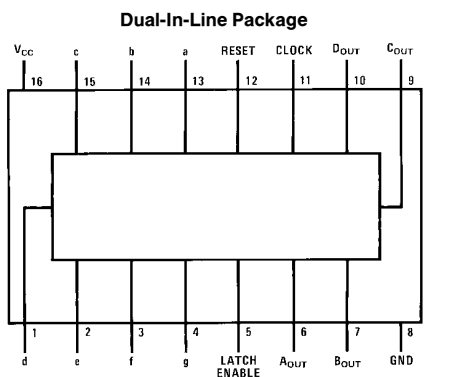

**Top View**  
Order Number MM74C925

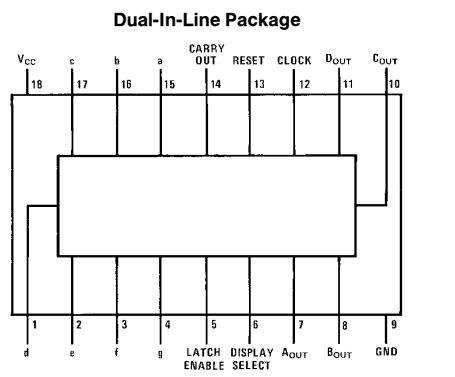

**Top View**  
Order Number MM74C926,  
MM74C927 or MM74C928

**MM74C925, MM74C926, MM74C927, MM74C928 4-Digit Counters  
with Multiplexed 7-Segment Output Drivers**

## Absolute Maximum Ratings (Note 1)

If Military/Aerospace specified devices are required, please contact the National Semiconductor Sales Office/Distributors for availability and specifications.

Voltage at Any Output Pin	GND – 0.3V to $V_{CC} + 0.3V$
Voltage at Any Input Pin	GND – 0.3V to +15V
Operating Temperature Range ( $T_A$ )	–40°C to +85°C

Storage Temperature Range	–65°C to +150°C
Power Dissipation ( $P_D$ )	Refer to $P_{D(MAX)}$ vs $T_A$ Graph
Operating $V_{CC}$ Range	3V to 6V
$V_{CC}$	6.5V
Lead Temperature (Soldering, 10 seconds)	260°C

## DC Electrical Characteristics Min/Max limits apply at –40°C ≤ $T_j$ ≤ +85°C, unless otherwise noted

Symbol	Parameter	Conditions	Min	Typ	Max	Units
<b>CMOS TO CMOS</b>						
$V_{IN(1)}$	Logical “1” Input Voltage	$V_{CC} = 5V$	3.5			V
$V_{IN(0)}$	Logical “0” Input Voltage	$V_{CC} = 5V$			1.5	V
$V_{OUT(1)}$	Logical “1” Output Voltage (Carry-Out and Digit Output Only)	$V_{CC} = 5V, I_O = -10 \mu A$	4.5			V
$V_{OUT(0)}$	Logical “0” Output Voltage	$V_{CC} = 5V, I_O = 10 \mu A$			0.5	V
$I_{IN(1)}$	Logical “1” Input Current	$V_{CC} = 5V, V_{IN} = 15V$		0.005	1	$\mu A$
$I_{IN(0)}$	Logical “0” Input Current	$V_{CC} = 5V, V_{IN} = 0V$	–1	–0.005		$\mu A$
$I_{CC}$	Supply Current	$V_{CC} = 5V$ , Outputs Open Circuit, $V_{IN} = 0V$ or 5V		20	1000	$\mu A$
<b>CMOS/LPTTL INTERFACE</b>						
$V_{IN(1)}$	Logical “1” Input Voltage	$V_{CC} = 4.75V$	$V_{CC} - 2$			V
$V_{IN(0)}$	Logical “0” Input Voltage	$V_{CC} = 4.75V$			0.8	V
$V_{OUT(1)}$	Logical “1” Output Voltage (Carry-Out and Digit Output Only)	$V_{CC} = 4.75V$ , $I_O = -360 \mu A$	2.4			V
$V_{OUT(0)}$	Logical “0” Output Voltage	$V_{CC} = 4.75V, I_O = 360 \mu A$			0.4	V
<b>OUTPUT DRIVE</b>						
$V_{OUT}$	Output Voltage (Segment Sourcing Output)	$I_{OUT} = -65 mA, V_{CC} = 5V, T_j = 25^\circ C$ $I_{OUT} = -40 mA, V_{CC} = 5V$ { $T_j = 100^\circ C$ $T_j = 150^\circ C$	$V_{CC} - 2$ $V_{CC} - 1.6$ $V_{CC} - 2$	$V_{CC} - 1.3$ $V_{CC} - 1.2$ $V_{CC} - 1.4$		V V V
$R_{ON}$	Output Resistance (Segment Sourcing Output)  Output Resistance (Segment Output) Temperature Coefficient	$I_{OUT} = -65 mA, V_{CC} = 5V, T_j = 25^\circ C$ $I_{OUT} = -40 mA, V_{CC} = 5V$ { $T_j = 100^\circ C$ $T_j = 150^\circ C$		20 30 35 0.6	32 40 50 0.8	$\Omega$ $\Omega$ $\Omega$ %/°C
$I_{SOURCE}$	Output Source Current (Digit Output)	$V_{CC} = 4.75V, V_{OUT} = 1.75V, T_j = 150^\circ C$	–1	–2		mA
$I_{SOURCE}$	Output Source Current (Carry-Out)	$V_{CC} = 5V, V_{OUT} = 0V, T_j = 25^\circ C$	–1.75	–3.3		mA
$I_{SINK}$	Output Sink Current (All Outputs)	$V_{CC} = 5V, V_{OUT} = V_{CC}, T_j = 25^\circ C$	1.75	3.6		mA
$\theta_{JA}$	Thermal Resistance	MM74C925 (Note 4) MM74C926, MM74C927, MM74C928		75 70	100 90	°C/W °C/W

**Note 1:** “Absolute Maximum Ratings” are those values beyond which the safety of the device cannot be guaranteed. Except for “Operating Temperature Range” they are not meant to imply that the devices should be operated at these limits. The table of “Electrical Characteristics” provides conditions for actual device operation.

**Note 2:** Capacitance is guaranteed by periodic testing.

**Note 3:**  $C_{PD}$  determines the no load AC power consumption of any CMOS device. For complete explanation see 54C/74C Family Characteristics application note, AN-90.

**Note 4:**  $\theta_{JA}$  measured in free-air with device soldered into printed circuit board.

## AC Electrical Characteristics\* $T_A = 25^\circ\text{C}$ , $C_L = 50\text{ pF}$ , unless otherwise noted

Symbol	Parameter	Conditions	Min	Typ	Max	Units
$f_{\text{MAX}}$	Maximum Clock Frequency	$V_{\text{CC}} = 5\text{V}$ , Square Wave Clock $T_j = 25^\circ\text{C}$ $T_j = 100^\circ\text{C}$	2 1.5	4 3		MHz MHz
$t_r, t_f$	Maximum Clock Rise or Fall Time	$V_{\text{CC}} = 5\text{V}$			15	$\mu\text{s}$
$t_{\text{WR}}$	Reset Pulse Width	$V_{\text{CC}} = 5\text{V}$ $T_j = 25^\circ\text{C}$ $T_j = 100^\circ\text{C}$	250 320	100 125		ns ns
$t_{\text{WLE}}$	Latch Enable Pulse Width	$V_{\text{CC}} = 5\text{V}$ $T_j = 25^\circ\text{C}$ $T_j = 100^\circ\text{C}$	250 320	100 125		ns ns
$t_{\text{SET(CK, LE)}}$	Clock to Latch Enable Set-Up Time	$V_{\text{CC}} = 5\text{V}$ $T_j = 25^\circ\text{C}$ $T_j = 100^\circ\text{C}$	2500 3200	1250 1600		ns ns
$t_{\text{LR}}$	Latch Enable to Reset Wait Time	$V_{\text{CC}} = 5\text{V}$ $T_j = 25^\circ\text{C}$ $T_j = 100^\circ\text{C}$	0 0	-100 -100		ns ns
$t_{\text{SET(R, LE)}}$	Reset to Latch Enable Set-Up Time	$V_{\text{CC}} = 5\text{V}$ $T_j = 25^\circ\text{C}$ $T_j = 100^\circ\text{C}$	320 400	160 200		ns ns
$f_{\text{MUX}}$	Multiplexing Output Frequency	$V_{\text{CC}} = 5\text{V}$		1000		Hz
$C_{\text{IN}}$	Input Capacitance	Any Input (Note 2)		5		pF

\*AC Parameters are guaranteed by DC correlated testing.

## Functional Description

Reset — Asynchronous, active high  
 Display Select — High, displays output of counter  
 Low, displays output of latch  
 Latch Enable — High, flow through condition  
 Low, latch condition  
 Clock — Negative edge sensitive

Segment Output — Current sourcing with 40 mA @  $V_{\text{OUT}} = V_{\text{CC}} - 1.6\text{V}$  (typ.) Also, sink capability = 2 LTTL loads

Digit Output — Current sourcing with 1 mA @  $V_{\text{OUT}} = 1.75\text{V}$ . Also, sink capability = 2 LTTL loads

Carry-Out — 2 LTTL loads. See carry-out waveforms.

## Typical Performance Characteristics

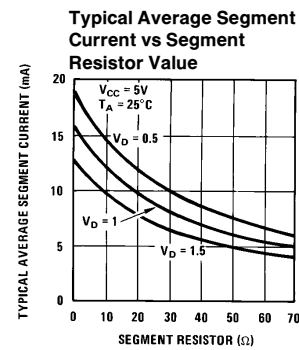
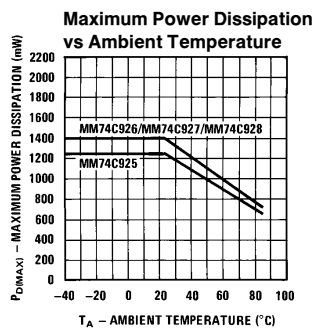
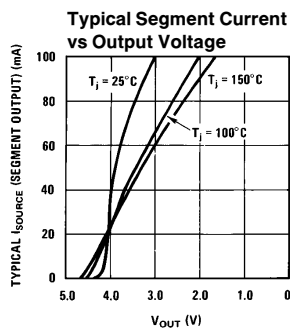

Note:  $V_D$  = Voltage across digit driver

TL/F/5919-3

# Logic and Block Diagrams

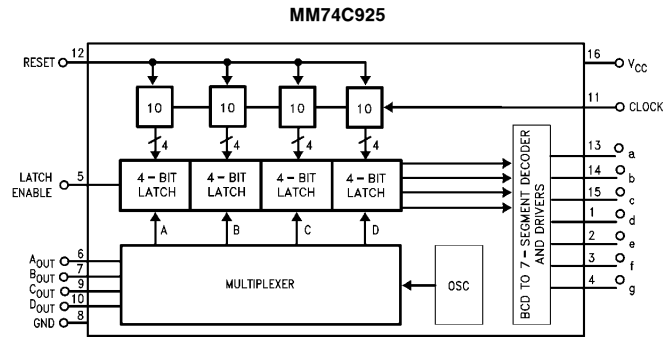

TL/F/5919-4

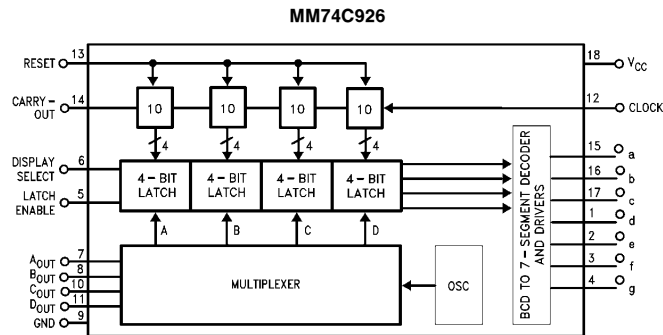

TL/F/5919-5

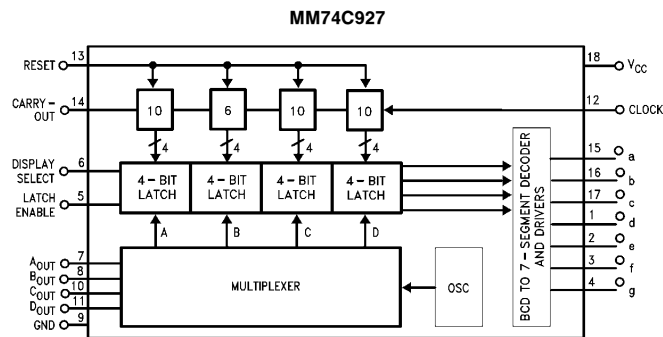

TL/F/5919-6

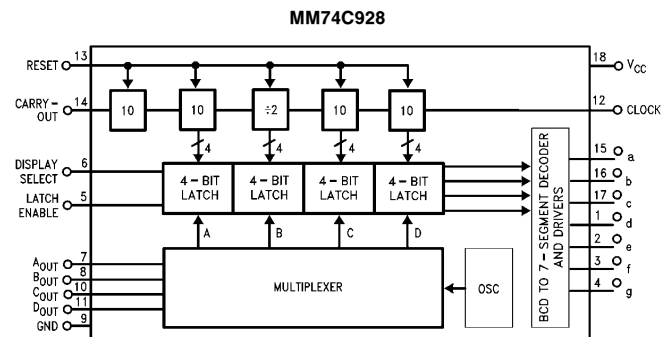

TL/F/5919-7

## Logic and Block Diagrams (Continued)

Segment Output Driver

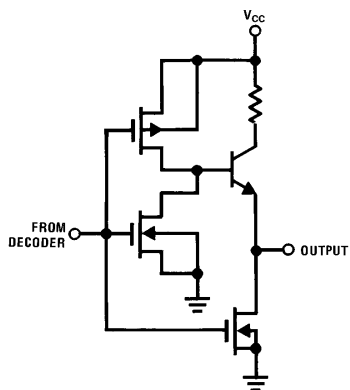

TL/F/5919-8

Input Protection

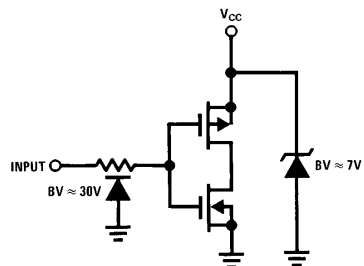

TL/F/5919-9

Common Cathode LED Display

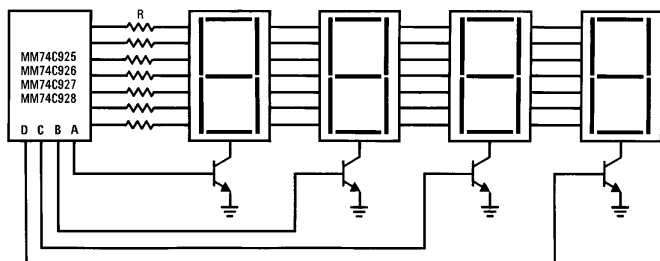

TL/F/5919-10

Segment Identification

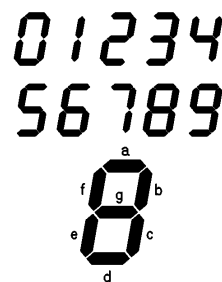

TL/F/5919-11

## Switching Time Waveforms

Input Waveforms

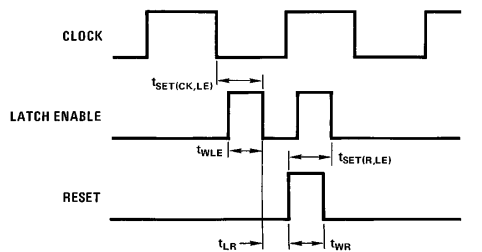

TL/F/5919-12

Multiplexing Output Waveforms

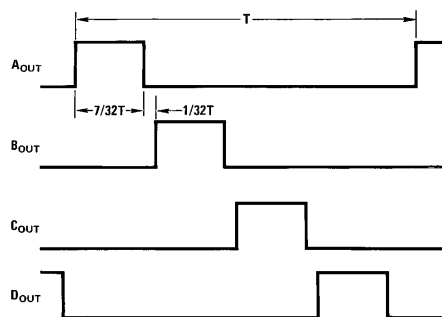

TL/F/5919-13

$$T = 1/f_{MUX}$$

## Switching Time Waveforms (Continued)

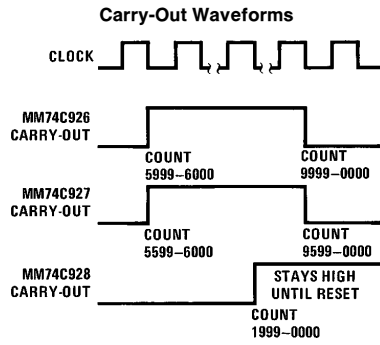

TL/F/5919-14

## Physical Dimensions inches (millimeters)

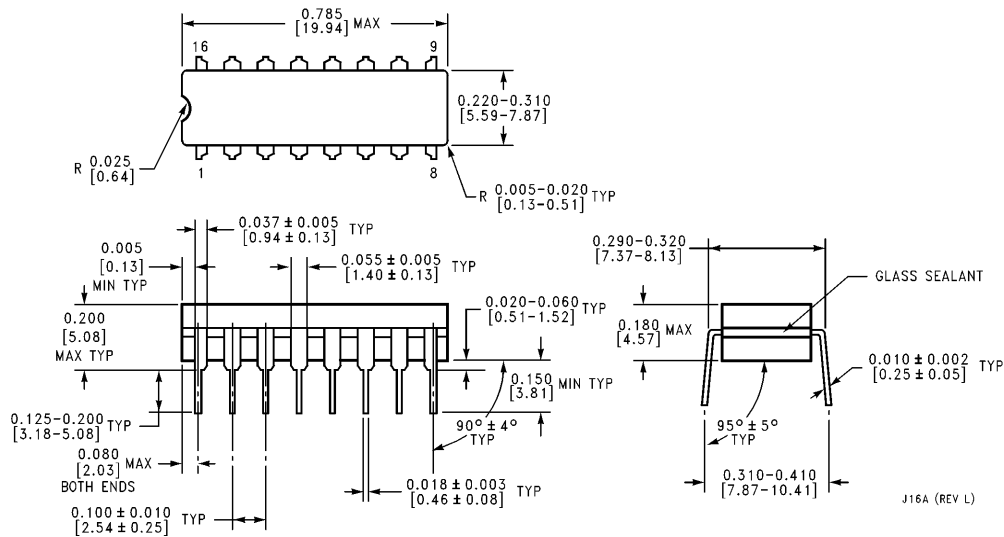

**Ceramic Dual-In-Line Package (J)**  
**Order Number MM74C925J**  
**NS Package Number J16A**

**Physical Dimensions** inches (millimeters) (Continued)

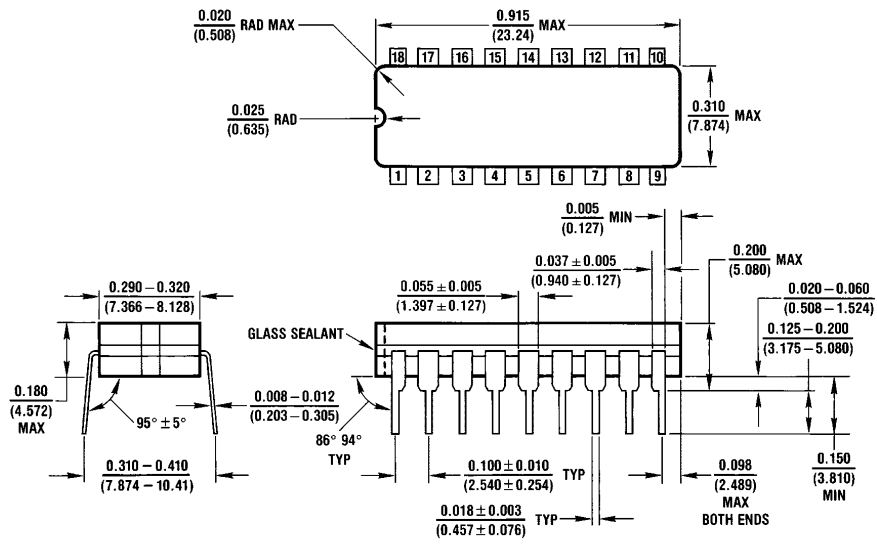

**Ceramic Dual-In-Line Package (J)**  
**Order Number MM74C926J, MM74C927J or MM74C928J**  
**NS Package Number J18A**

J18A (REV L)

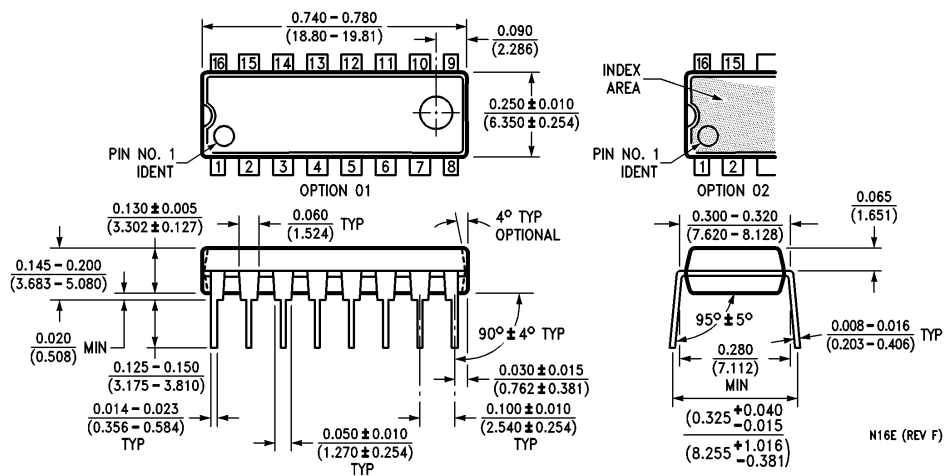

**Molded Dual-In-Line Package (N)**  
**Order Number MM74C925N**  
**NS Package Number N16E**

N16E (REV F)

**MM74C925, MM74C926, MM74C927, MM74C928 4-Digit Counters  
with Multiplexed 7-Segment Output Drivers**

**Physical Dimensions** inches (millimeters) (Continued)

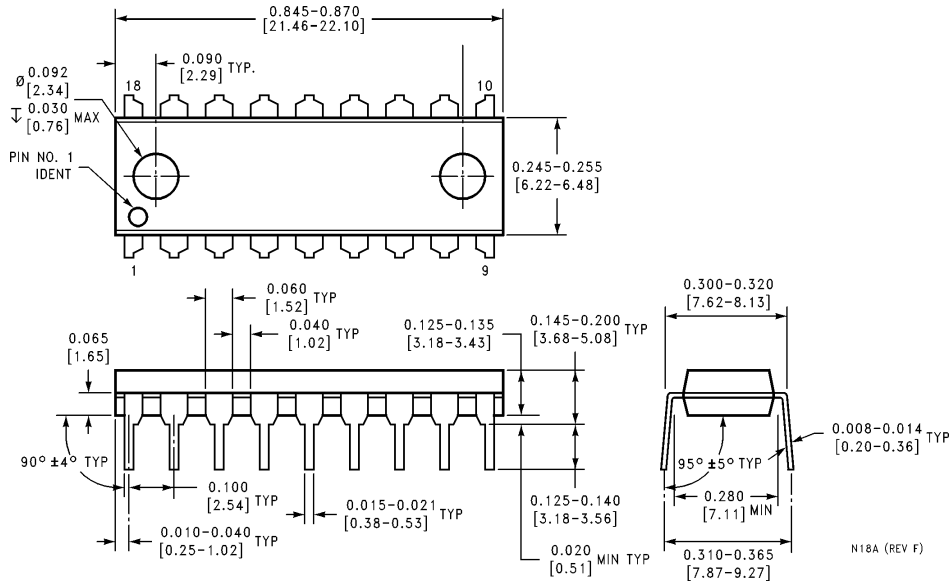

**Molded Dual-In-Line Package (N)**  
**Order Number MM74C926N, MM74C927N or MM74C928N**  
**NS Package Number N18A**

N18A (REV F)

**LIFE SUPPORT POLICY**

NATIONAL'S PRODUCTS ARE NOT AUTHORIZED FOR USE AS CRITICAL COMPONENTS IN LIFE SUPPORT DEVICES OR SYSTEMS WITHOUT THE EXPRESS WRITTEN APPROVAL OF THE PRESIDENT OF NATIONAL SEMICONDUCTOR CORPORATION. As used herein:

1. Life support devices or systems are devices or systems which, (a) are intended for surgical implant into the body, or (b) support or sustain life, and whose failure to perform, when properly used in accordance with instructions for use provided in the labeling, can be reasonably expected to result in a significant injury to the user.
2. A critical component is any component of a life support device or system whose failure to perform can be reasonably expected to cause the failure of the life support device or system, or to affect its safety or effectiveness.



**National Semiconductor Corporation**  
 1111 West Bardin Road  
 Arlington, TX 76017  
 Tel: 1(800) 272-9959  
 Fax: 1(800) 737-7018

**National Semiconductor Europe**  
 Fax: (+49) 0-180-530 85 86  
 Email: onjwge@tevm2.nsc.com  
 Deutsch Tel: (+49) 0-180-530 85 85  
 English Tel: (+49) 0-180-532 78 32  
 Français Tel: (+49) 0-180-532 93 58  
 Italiano Tel: (+49) 0-180-534 16 80

**National Semiconductor Hong Kong Ltd.**  
 19th Floor, Straight Block,  
 Ocean Centre, 5 Canton Rd.  
 Tsimshatsui, Kowloon  
 Hong Kong  
 Tel: (852) 2737-1600  
 Fax: (852) 2736-9960

**National Semiconductor Japan Ltd.**  
 Tel: 81-043-299-2309  
 Fax: 81-043-299-2408

National does not assume any responsibility for use of any circuitry described, no circuit patent licenses are implied and National reserves the right at any time without notice to change said circuitry and specifications.