

SN54159, SN74159 4-LINE TO 16-LINE DECODERS/DEMULTIPLEXERS WITH OPEN-COLLECTOR OUTPUTS

DECEMBER 1972 - REVISED MARCH 1988

- Open-Collector Outputs for Interfacing with MOS or Memory Decoders/Drivers
- Decodes 4 Binary-Coded Inputs into One of 16 Mutually Exclusive Outputs
- Performs the Demultiplexing Function by Distributing Data from One Input Line to Any One of 16 Outputs
- Typical Average Propagation Delay Times:
24 ns through 3 levels of Logic
19 ns from Strobe Input
- Output Off-State Current is Less Than 50 μ A
- Fully Compatible with Most TTL and MSI Circuits

SN54159 . . . J OR W PACKAGE
SN74159 . . . N PACKAGE

(TOP VIEW)

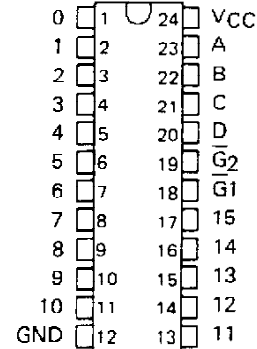

description

Each of these monolithic, 4-line-to-16 line decoders utilizes TTL circuitry to decode four binary-coded inputs into one of sixteen mutually exclusive open-collector outputs when both the strobe inputs, $\bar{G}1$ and $\bar{G}2$, are low. The demultiplexing function is performed by using the 4 input lines to address the output line, passing data from one of the strobe inputs with the other strobe input low. When either strobe input is high, all outputs are high. These demultiplexers are ideally suited for implementing MOS memory decoding or for interfacing with discrete memory address drivers. For ultra-high-speed applications, the SN54S138/SN74S138 or SN54S139/SN74S139 is recommended.

These circuits are fully compatible for use with most other TTL circuits. Input clamping diodes are provided to minimize transmission-line effects and thereby simplify system design. Input buffers are used to lower the fan-in requirement to only one normalized Series 54/74 load. A fan-out to 10 normalized Series 54/74 loads in the low-level state is available from each of the sixteen outputs. Typical power dissipation is 170 mW.

The SN54159 is characterized for operation over the full military temperature range of -55°C to 125°C ; the SN74159 is characterized for operation from 0°C to 70°C .

logic symbols (alternatives)[†]

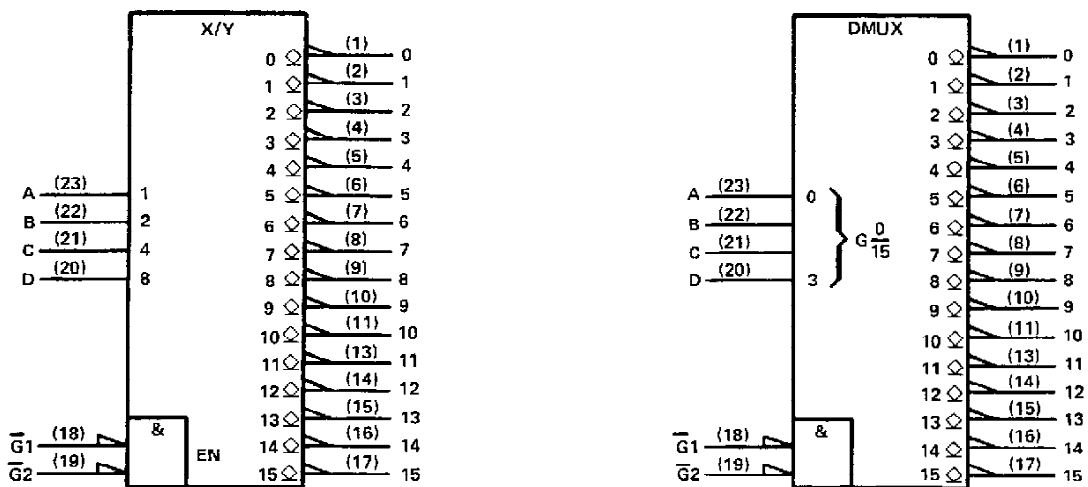

[†]These symbols are in accordance with ANSI/IEEE Std 91-1984 and IEC Publication 617-12.

PRODUCTION DATA documents contain information current as of publication date. Products conform to specifications per the terms of Texas Instruments standard warranty. Production processing does not necessarily include testing of all parameters.



SN54159, SN74159
4-LINE TO 16-LINE DECODERS/DEMULTIPLEXERS
WITH OPEN-COLLECTOR OUTPUTS

FUNCTION TABLE

		INPUTS				OUTPUTS															
$\bar{G}1$	$\bar{G}2$	D	C	B	A	0	1	2	3	4	5	6	7	8	9	10	11	12	13	14	15
L	L	L	L	L	L	L	H	H	H	H	H	H	H	H	H	H	H	H	H	H	H
L	L	L	L	L	H	H	L	H	H	H	H	H	H	H	H	H	H	H	H	H	H
L	L	L	L	H	L	H	H	L	H	H	H	H	H	H	H	H	H	H	H	H	H
L	L	L	L	H	H	H	H	L	H	H	H	H	H	H	H	H	H	H	H	H	H
L	L	L	H	L	L	H	H	H	H	L	H	H	H	H	H	H	H	H	H	H	H
L	L	L	H	H	L	H	H	H	H	H	L	H	H	H	H	H	H	H	H	H	H
L	L	L	H	H	H	H	H	H	H	H	H	L	H	H	H	H	H	H	H	H	H
L	L	H	L	L	L	H	H	H	H	H	H	H	L	H	H	H	H	H	H	H	H
L	L	H	L	L	H	H	H	H	H	H	H	H	H	L	H	H	H	H	H	H	H
L	L	H	L	H	L	H	H	H	H	H	H	H	H	H	L	H	H	H	H	H	H
L	L	H	H	L	L	H	H	H	H	H	H	H	H	H	H	L	H	H	H	H	H
L	L	H	H	L	H	H	H	H	H	H	H	H	H	H	H	H	L	H	H	H	H
L	L	H	H	H	L	H	H	H	H	H	H	H	H	H	H	H	H	L	H	H	H
L	L	H	H	H	H	H	H	H	H	H	H	H	H	H	H	H	H	H	L	H	H
L	H	X	X	X	X	H	H	H	H	H	H	H	H	H	H	H	H	H	H	H	H
H	L	X	X	X	X	H	H	H	H	H	H	H	H	H	H	H	H	H	H	H	H
H	H	X	X	X	X	H	H	H	H	H	H	H	H	H	H	H	H	H	H	H	H

H = high level, L = low level, X = irrelevant

logic diagram

Same as SN54154, SN74154.

absolute maximum ratings over operating free-air temperature range (unless otherwise noted)

Supply voltage, V_{CC} (see Note 1)	7 V
Input voltage	5.5 V
Off-state output voltage	5.5 V
Operating free-air temperature range: SN54159 Circuits	-55°C to 125°C
SN74159 Circuits	0°C to 70°C
Storage temperature range	-65°C to 150°C

NOTE 1: Voltage values are with respect to network ground terminal.



SN54159, SN74159

4-LINE TO 16-LINE DECODERS/DEMULTIPLEXERS WITH OPEN-COLLECTOR OUTPUTS

recommended operating conditions

	SN54159			SN74159			UNIT	
	MIN	NOM	MAX	MIN	NOM	MAX		
Supply voltage, V_{CC}	4.5	5	5.5	4.75	5	5.25	V	
Low-level output current, I_{OL}	16			16			mA	
Operating free-air temperature, T_A	- 55			125			0 70	$^{\circ}$ C

electrical characteristics over recommended operating free-air temperature range (unless otherwise noted)

PARAMETER	TEST CONDITIONS†	MIN	TYP‡	MAX	UNIT
V_{IH} High-level input voltage		2			V
V_{IL} Low-level input voltage				0.8	V
V_{IK} Input clamp voltage	$V_{CC} = \text{MIN}$, $I_I = -12 \text{ mA}$			-1.5	V
I_{OH} High-level output current	$V_{CC} = \text{MIN}$, $V_{IH} = 2 \text{ V}$, $V_{IL} = 0.8 \text{ V}$, $V_{OH} = 5.5 \text{ V}$			50	μ A
V_{OL} Low-level output voltage	$V_{CC} = \text{MIN}$, $V_{IH} = 2 \text{ V}$, $V_{IL} = 0.8 \text{ V}$, $I_{OL} = 16 \text{ mA}$			0.4	V
I_I Input current at maximum input voltage	$V_{CC} = \text{MAX}$, $V_I = 5.5 \text{ V}$			1	mA
I_{IH} High-level input current	$V_{CC} = \text{MAX}$, $V_I = 2.4 \text{ V}$			40	μ A
I_{IL} Low-level input current	$V_{CC} = \text{MAX}$, $V_I = 0.4 \text{ V}$			-1.6	mA
I_{CC} Supply current	$V_{CC} = \text{MAX}$, All inputs grounded		34	56	mA

† For conditions shown as MIN or MAX, use the appropriate value specified under recommended operating conditions for the applicable type.

‡ All typical values are at $V_{CC} = 5 \text{ V}$, $T_A = 25^{\circ}\text{C}$.

switching characteristics, $V_{CC} = 5 \text{ V}$, $T_A = 25^{\circ}\text{C}$

PARAMETER	TEST CONDITIONS	MIN	TYP	MAX	UNIT
t_{PLH} Propagation delay time, low-to-high-level output, from A, B, C, or D inputs through 3 levels of logic	$C_L = 15 \text{ pF}$, $R_L = 400 \Omega$, See Note 2		23	36	ns
t_{PHL} Propagation delay time, high-to-low-level output, from A, B, C, or D inputs through 3 levels of logic			24	36	ns
t_{PLH} Propagation delay time, low-to-high-level output, from either strobe input			15	25	ns
t_{PHL} Propagation delay time, high-to-low-level output, from either strobe input			22	36	ns

NOTE 2: Load circuits and voltage waveforms are shown in Section 1.

schematics of inputs and outputs

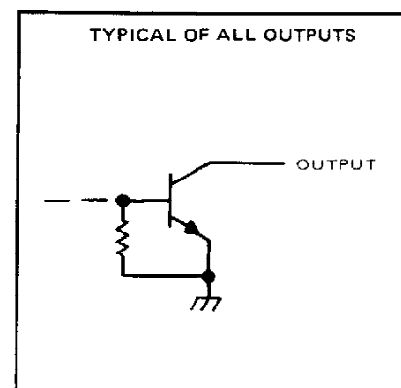
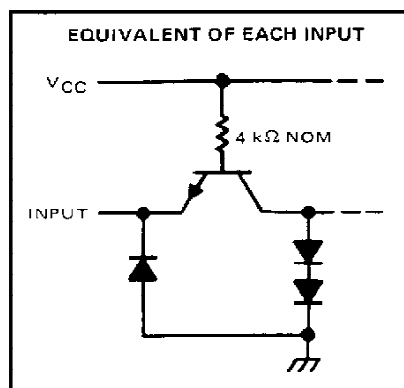

**TEXAS
INSTRUMENTS**

POST OFFICE BOX 455012 • DALLAS, TEXAS 75265