

Typical Applications

- Digital and Analog Receivers and Transmitters
- High Data Rate Digital Communications
- Spread-Spectrum Communication Systems
- Interactive Cable Systems
- Portable Battery-Powered Equipment

Product Description

The RF2713 is a monolithic integrated quadrature modulator/demodulator. The demodulator is used to recover the I and Q baseband signals from the amplified and filtered IF. Likewise, the inputs and outputs can be reconfigured to modulate I/Q signals onto an RF carrier. The RF2713 is intended for IF systems where the IF frequency ranges from 100kHz to 250MHz, and the LO frequency is two times the IF. The IC contains all of the required components to implement the modulation/demodulation function and contains a digital divider type 90° phase shifter, two double balanced mixers, and baseband amplifiers designed to interface with Analog to Digital Converters. The unit operates from a single 3V to 6V power supply.

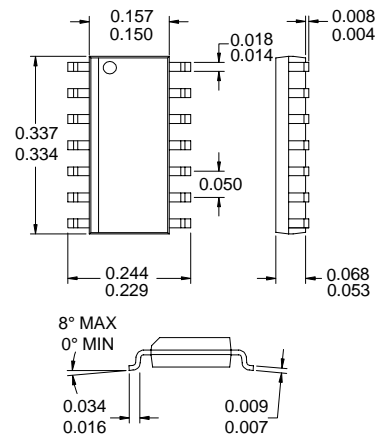

5
MODULATORS AND
UPCONVERTERS

Optimum Technology Matching® Applied

- | | | |
|--|-----------------------------------|--------------------------------------|
| <input type="checkbox"/> Si BJT | <input type="checkbox"/> GaAs HBT | <input type="checkbox"/> GaAs MESFET |
| <input checked="" type="checkbox"/> Si Bi-CMOS | <input type="checkbox"/> SiGe HBT | <input type="checkbox"/> Si CMOS |

Package Style: SOIC-14

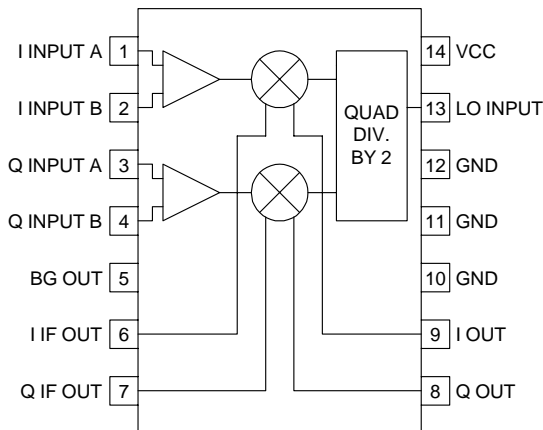

Functional Block Diagram

Features

- 3V to 6V Operation
- Modulation or Demodulation
- IF From 100kHz to 250MHz
- Baseband From DC to 50MHz
- Digital LO Quadrature Divider
- Low Power and Small Size

Ordering Information

- RF2713 Quadrature Modulator/Demodulator
- RF2713 PCBA-D Fully Assembled Evaluation Board (Demodulator)
- RF2713 PCBA-M Fully Assembled Evaluation Board (Modulator)

RF Micro Devices, Inc.
7625 Thorndike Road
Greensboro, NC 27409, USA

Tel (336) 664 1233
Fax (336) 664 0454
<http://www.rfmd.com>

Absolute Maximum Ratings

Parameter	Rating	Unit
Supply Voltage	-0.5 to 7.0	V _{DC}
IF Input Level	500	mV _{PP}
Operating Ambient Temperature	-40 to +85	°C
Storage Temperature	-40 to +150	°C



Caution! ESD sensitive device.

RF Micro Devices believes the furnished information is correct and accurate at the time of this printing. However, RF Micro Devices reserves the right to make changes to its products without notice. RF Micro Devices does not assume responsibility for the use of the described product(s).

5
MODULATORS AND
UPCONVERTERS

Parameter	Specification			Unit	Condition
	Min.	Typ.	Max.		
Overall					T=25°C, V _{CC} =3.0V, IF=100MHz, LO=200MHz, F _{MOD} =500kHz
IF Frequency Range		0.1 to 250		MHz	For IF frequencies below ~2.5MHz, the LO should be a square wave. IF frequencies lower than 100kHz are attainable if the LO is a square wave and sufficiently large DC blocking capacitors are used.
Baseband Frequency Range		DC to 50		MHz	
Input Impedance		1200 1pF		Ω	Each input, single-ended
LO					
Frequency					Twice (2x) the IF frequency. For IF frequencies below ~2.5MHz, the LO should be a square wave. IF frequencies lower than 100kHz are attainable if the LO is a square wave and sufficiently large DC blocking capacitors are used.
Level		0.06 to 1		V _{PP}	
Input Impedance		500 1pF		Ω	
Demodulator Configuration					IF _{IN} =28mV _{PP} , LO=200mV _{PP} , Z _{LOAD} =10kΩ
Output Impedance		50 1pF		Ω	Each output, I _{OUT} and Q _{OUT}
Maximum Output		1.4		V _{PP}	Saturated
Voltage Gain		20		dB	V _{CC} =3.0V
	22.5	24	25.1	dB	V _{CC} =5.0V
Noise Figure		24		dB	Single Sideband, IF Input of device reactively matched
		35		dB	Single Sideband, 50Ω shunt resistor at IF Input
Input Third Order Intercept Point (IIP ₃)		-22		dBm	V _{CC} =3.0V, IF Input of device reactively matched
		-11		dBm	V _{CC} =3.0V, 50Ω shunt resistor at IF Input
		-19			V _{CC} =5.0V, IF Input of device reactively matched
		-8		dBm	V _{CC} =5.0V, 50Ω shunt resistor at IF Input
		-28		dBm	V _{CC} =5.0V, IF Input of device reactively matched, Z _{LOAD} =50Ω
I/Q Amplitude Balance		0.1	0.5	dB	
Quadrature Phase Error		1		°	
DC Output		800		mV	V _{CC} =3.0V, I _{OUT} and Q _{OUT} to GND
	2.0	2.4	2.8	V	V _{CC} =5.0V, I _{OUT} and Q _{OUT} to GND
DC Offset		<10	100	mV	I _{OUT} to Q _{OUT}

Parameter	Specification			Unit	Condition
	Min.	Typ.	Max.		
Modulator Configuration					IF _{IN} =28mV _{PP} , LO=200mV _{PP} , Z _{LOAD} =1200Ω Saturated Single Sideband, 1 dB Gain Compression. Single Sideband Unadjusted. Carrier Suppression may be optimized further by adjusting the DC offset level between the A and B inputs.
Maximum Output		200		mV _{PP}	
Input Voltage		90		mV _{PP}	
Voltage Gain		6		dB	
I/Q Amplitude Balance		0.1		dB	
Quadrature Phase Error		<±1		°	
Carrier Suppression		25		dBc	
Sideband Suppression		30		dBc	
Power Supply					Operating limits V _{CC} =3.0V V _{CC} =5.0V
Voltage		2.7 to 6		V	
Current		8		mA	
	8	10	12	mA	

Pin	Function	Description (Demodulator Configuration)	Interface Schematic
1	I INPUT A	<p>When the RF2713 is configured as a Quadrature Demodulator, both mixers are driven by the IF. Whether driving the mixers single-endedly (as shown in the application schematic) or differentially, the A Inputs (pins 1 and 3) should be connected to each other. Likewise, both B Inputs (pins 2 and 4) should be connected to each other. This ensures that the IF will reach each mixer with the same amplitude and phase, yielding the best I and Q output amplitude and quadrature balance. Note that connecting the inputs in parallel changes the input impedance (see the Gilbert Cell mixer equivalent circuit). The single-ended input impedance (as shown in the application circuit) becomes 630Ω, but in the balanced configuration, the input impedance would remain 1260Ω.</p> <p>The mixers are Gilbert Cell designs with balanced inputs. The equivalent schematic for one of the mixers is shown on the following page. The input impedance of each pin is determined by the 1260Ω resistor to V_{CC} in parallel with a transistor base. Note from the schematic that all four input pins have an internally set DC bias. For this reason, all four inputs (pins 1 through 4) should be DC blocked. The capacitance values of the blocking capacitors is determined by the IF frequency. When driving single-endedly, both the series (pins 1 and 3) and shunt (pins 2 and 4) blocking capacitors should be low impedances, relative to the 630Ω input impedance.</p>	
2	I INPUT B	Same as pin 1, except complementary input.	See pin 1.
3	Q INPUT A	Same as pin 1, except Q Buffer Amplifier.	See pin 1.
4	Q INPUT B	Same as pin 3, except complementary input.	See pin 1.
5	BG OUT	Band Gap voltage reference output. This voltage output is held constant over variations in supply voltage and operating temperature and may be used as a reference for other external circuitry. This pin should not be loaded such that the sourced current exceeds 1 mA. This pin should be bypassed with a large (0.1 μF) capacitor.	
6	I IF OUT	This pin is not used in the Demodulator Configuration, but must be connected to V _{CC} in order to properly bias the I mixer.	
7	Q IF OUT	Same as pin 6, except Q mixer.	Same as pin 6.
8	Q OUT	Q Mixer's Baseband Output. This pin is NOT internally DC blocked and has DC present due to internal biasing. This is an emitter-follower type output with an internal 2kΩ pull-down resistor. Even though the AC output impedance is ~50Ω, this pin is intended to drive only high impedance loads such as an opamp or an ADC. The output transistor is NOT biased such that it can drive a large signal into a 50Ω load. DC coupling of this output is permitted provided that the DC impedance to ground, which appears in parallel with the internal pull-down resistor, is significantly greater than 2kΩ.	
9	I OUT	Same as pin 8, except Q Mixer's Baseband Output.	Same as pin 8.
10	GND	Ground connection. Keep traces physically short and connect immediately to ground plane for best performance.	
11	GND	Same as pin 10.	
12	GND	Same as pin 10.	

Pin	Function	Description (Demodulator Configuration)	Interface Schematic
13	LO INPUT	High impedance, single-ended modulator LO input. The LO applied to this pin is frequency divided by a factor of 2 and becomes the "Carrier". For direct demodulation, the Carrier is equal in frequency to the center of the input IF spectrum (except in the case of SSB/SC). The input impedance is determined by an internal 500Ω bias resistor to V _{CC} . An external blocking capacitor should be provided if the pin is connected to a device with DC present. Matching the input impedance is typically achieved by adding a 51Ω resistor to ground on the source side of the AC coupling capacitor. For the LO input, maximum power transfer is not critical. The internal LO switching circuits are controlled by the voltage, not power, into the part. In cases where the LO source does not have enough available voltage, a reactive match (voltage transformer) can be used. The LO circuitry consists of a limiting amplifier followed by a digital divider. The limiting amp ensures that the flip-flop type divider is driven with a square wave over a wide range of input levels. Because the flip-flop uses the rising and falling edges of the limiter output, the quadrature accuracy of the Carrier supplied to the mixers is directly related to the duty cycle, or equivalently to the even harmonic content, of the input LO signal. In particular, care should be taken to ensure that the 2xLO level input to this pin is at least 20dB below the LO level. Otherwise, the LO input is not sensitive to the type of input wave form, except for IF frequencies below ~2.5MHz, in which case the LO input should be a square wave, in order to ensure proper triggering of the flip-flops. IF frequencies below 100kHz are attainable if the LO is a square wave and sufficiently large DC blocking capacitors are used.	
14	VCC	Voltage supply for the entire device. This pin should be well bypassed at all frequencies (IF, LO, Carrier, Baseband) that are present in the part.	

Pin	Function	Description (Modulator Configuration)	Interface Schematic
1	I INPUT A	<p>When the RF2713 is configured as a Quadrature Modulator, each mixer is driven by an independent baseband modulation channel (I and Q). The mixers can be driven single-endedly (as shown in the modulator application circuit) or differentially. When driving single-endedly, the B Inputs (pins 2 and 4) should be connected to each other. This ensures that the baseband signals will reach each mixer with the same DC reference, yielding the best carrier suppression. Note that the input impedance changes according to the drive mode (see the mixer equivalent circuit on the previous page). The single-ended input impedance (as shown in the modulator application circuit) is 1200Ω for each of the two inputs. In the balanced configuration, the input impedance would be 2400Ω for each of the two inputs.</p> <p>The mixers are Gilbert Cell designs with balanced inputs. The equivalent schematic for one of the mixers is shown on the previous page. The input impedance of each pin is determined by the 1200Ω resistor to V_{CC} in parallel with a transistor base. Note from the schematic that all four input pins have an internally set DC bias. For this reason, all four inputs (pins 1 through 4) should be DC blocked. The capacitance values of the blocking capacitors is determined by the baseband frequency. When driving single-endedly, both the series (pins 1 and 3) and shunt (pins 2 and 4) blocking capacitors should be low impedances, relative to the input impedance.</p> <p>DC bias voltages may be supplied to the inputs pins, if required, in order to increase the amount of carrier suppression. For example, the DC levels on the reference inputs (pins 2 and 4) may be offset from each other by adding different resistor values to ground. These resistors should be larger than 2kΩ. Note from the mixer schematic that all four input pins have an internally set DC bias. If DC bias is to be supplied, the allowable ranges are limited. For 5V applications, the DC reference on both I pins or both Q pins must not go below 2.7V_{DC}, and in no case should the DC voltage on any of the four pins go below 2.0V_{DC} or above 5.5V_{DC}. If a DC reference is to be supplied, the source must also be capable of sinking current. If optimizing carrier suppression further is not a concern, it is recommended that all four inputs (pins 1 through 4) be DC blocked.</p>	
2	I INPUT B	Same as pin 1, except complementary input.	See pin 1.
3	Q INPUT A	Same as pin 1, except Q Buffer Amplifier.	See pin 1.
4	Q INPUT B	Same as pin 3, except complementary input.	See pin 1.
5	BG OUT	Band Gap voltage reference output. This voltage output is held constant over variations in supply voltage and operating temperature and may be used as a reference for other external circuitry. This pin should not be loaded such that the sourced current exceeds 1 mA. This pin should be bypassed with a large (0.1μF) capacitor.	
6	I IF OUT	Connecting pins 6 and 7 to each other accomplishes the summing function of the upconverted I and Q channels. In addition, because these outputs are open collector type, they must be connected to V _{CC} in order to properly bias the Gilbert Cell mixers. Maximum gain and output power occur when the load on these two pins is ~1200Ω. In most applications the impedance of the next stage will be lower and a reactive impedance transforming match should be used if maximum gain and output level are of concern. Biasing, DC blocking, and impedance transformation can simultaneously be achieved with the shunt-L / series-C topology shown in the Application Circuit. The inductance and capacitance values are chosen to achieve a specific impedance transforming ratio at a specific IF frequency. For applications where the gain is not as critical, a 1200Ω resistor may be added in parallel with a choke inductor in place of the matching inductor. If neither gain nor output level is critical, the inductor may be replaced with a resistor that sets the desired source impedance to drive the next stage. If the next stage is an "open" at DC, the blocking capacitor may be eliminated.	

Pin	Function	Description (Modulator Configuration)	Interface Schematic
7	Q IF OUT	Same as pin 6, except complementary input.	Same as pin 6.
8	Q OUT	Pins 8 and 9 are not used in a normal quadrature modulator application, and are left unconnected. Note, however, that the outputs of each of these pins are independent upconverted I and Q channels. These signals may be useful in other applications where independent IF channels are needed. Also note that these outputs are optimized as baseband outputs for the demodulator configuration. As a result, the gain rolls-off quickly with increasing frequency. This gain roll-off will limit the usefulness of these pins as independent I and Q upconverters. If these outputs are to be used, please refer to the Demodulator pin descriptions regarding load impedances.	
9	I OUT	Same as pin 8, except Q Mixer's Output.	Same as pin 8.
10	GND	Ground connection. Keep traces physically short and connect immediately to ground plane for best performance.	
11	GND	Same as pin 10.	
12	GND	Same as pin 10.	
13	LO INPUT	High impedance, single-ended modulator LO input. The LO applied to this pin is frequency divided by a factor of 2 and becomes the "Carrier". For modulation, the Carrier is the center of the modulated output spectrum (except in the case of SSB/SC). The input impedance is determined by an internal 500Ω bias resistor to V _{CC} . An external blocking capacitor should be provided if the pin is connected to a device with DC present. Matching the input impedance is typically achieved by adding a 51Ω resistor to ground on the source side of the AC coupling capacitor. For the LO input, maximum power transfer is not critical. The internal LO switching circuits are controlled by the voltage, not power, into the part. In cases where the LO source does not have enough available voltage, a reactive match (voltage transformer) can be used. The LO circuitry consists of a limiting amplifier followed by a digital divider. The limiting amp ensures that the flip-flop type divider is driven with a square wave over a wide range of input levels. Because the flip-flop uses the rising and falling edges of the limiter output, the quadrature accuracy of the Carrier supplied to the mixers is directly related to the duty cycle, or equivalently to the even harmonic content, of the input LO signal. In particular, care should be taken to ensure that the 2xLO level input to this pin is at least 20dB below the LO level. Otherwise, the LO input is not sensitive to the type of input wave form, except for IF frequencies below ~2.5MHz, in which case the LO input should be a square wave, in order to ensure proper triggering of the flip-flops. IF frequencies below 100kHz are attainable if the LO is a square wave and sufficiently large DC blocking capacitors are used.	
14	VCC	Voltage supply for the entire device. This pin should be well bypassed at all frequencies (IF, LO, Carrier, Baseband) that are present in the part.	

Gilbert Cell Mixer Equivalent Circuit

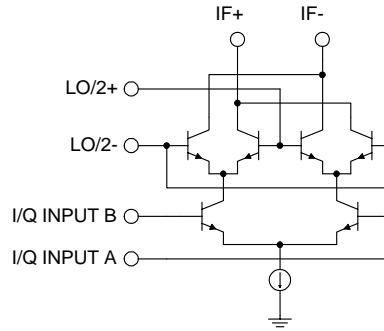

Application Schematic - Demodulator Configuration

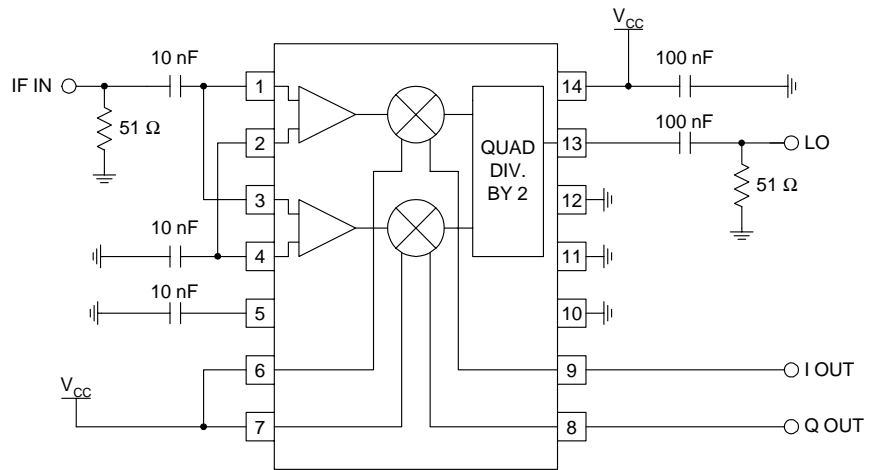

Application Schematic - Modulator Configuration

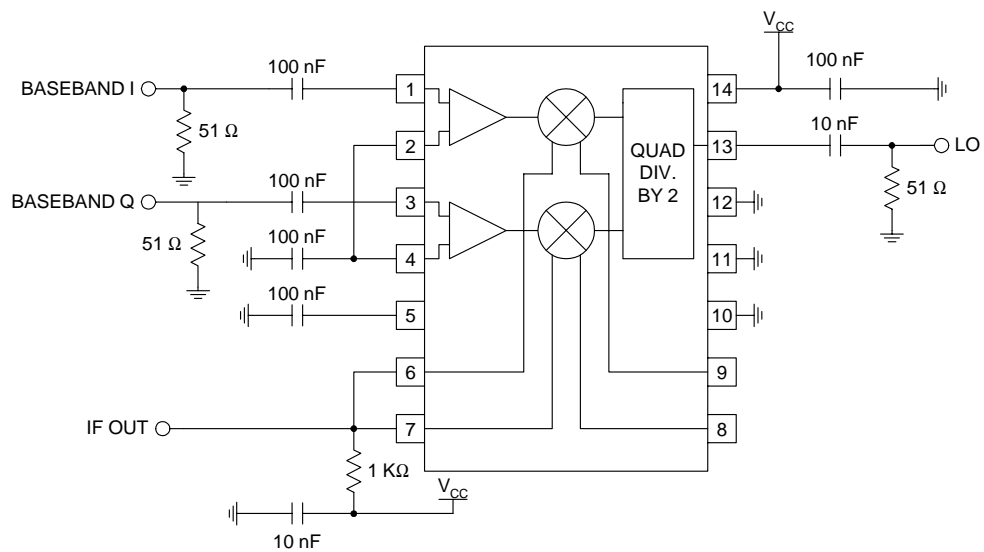

Evaluation Board Schematic - Demodulator Configuration

(Download [Bill of Materials](http://www.rfmd.com) from www.rfmd.com.)

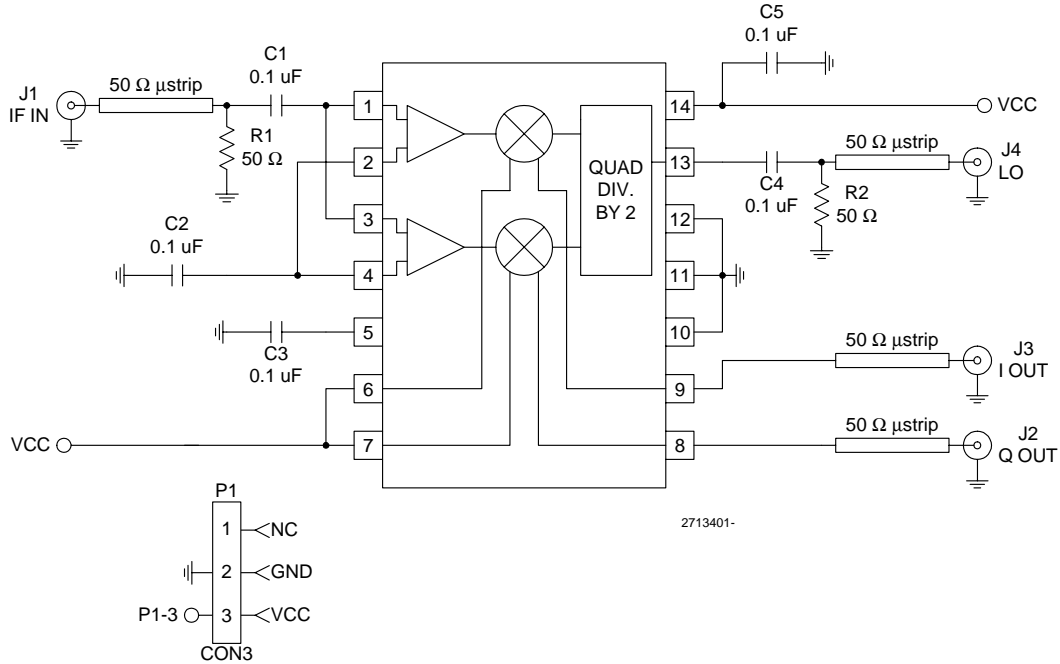

5

MODULATORS AND
UPCONVERTERS

Evaluation Board Schematic - Modulator Configuration

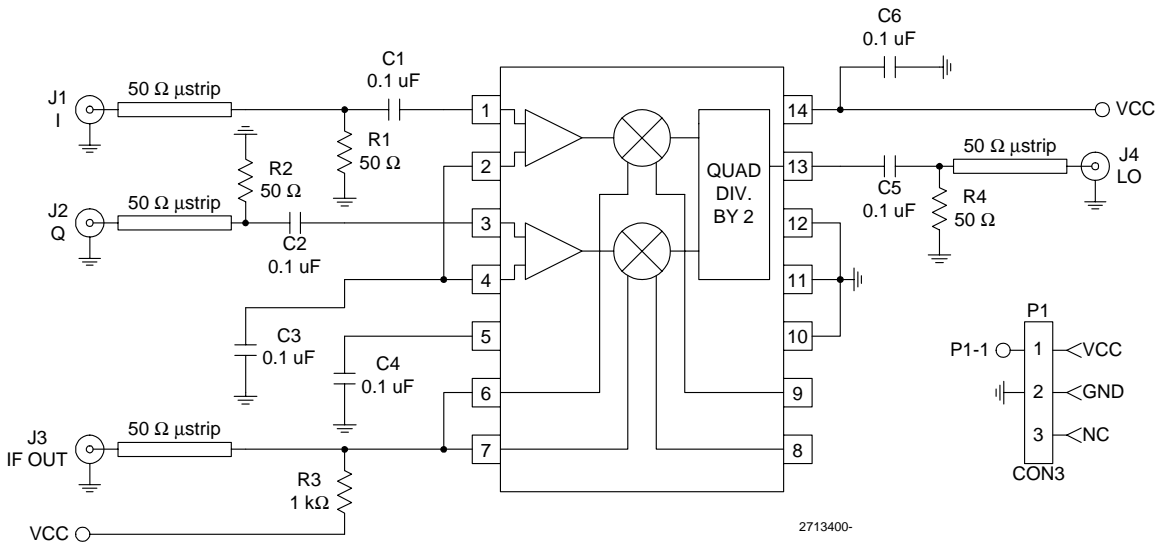

Evaluation Board Layout
Demodulator Configuration (2713 PCBA-D)
Board Size 2.0" x 2.0"
Board Thickness 0.031", Board Material FR-4

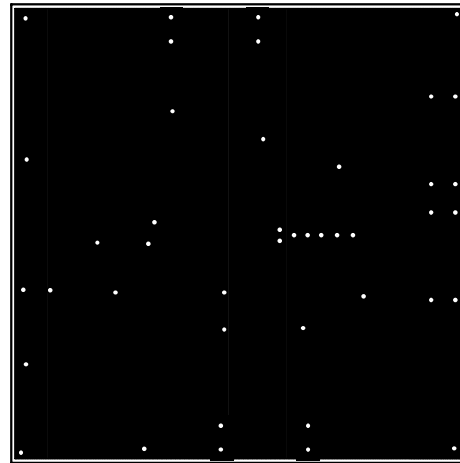
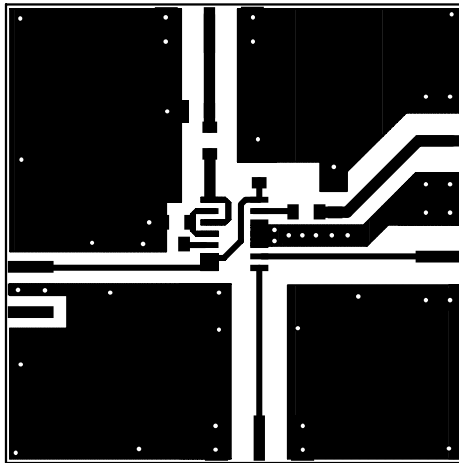
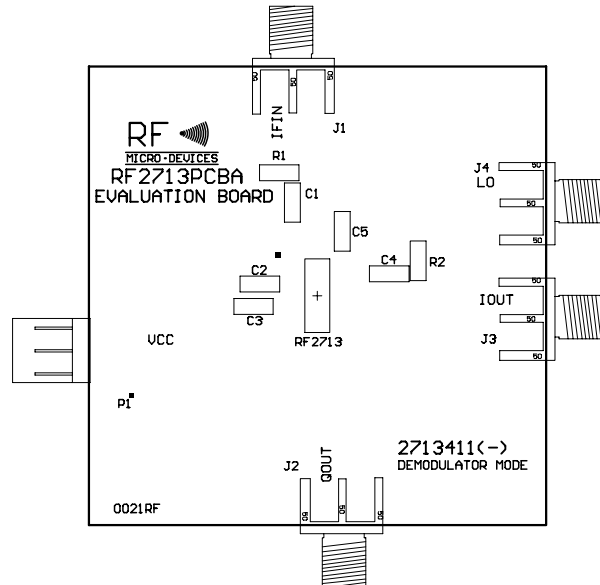

Evaluation Board Layout
Modulator Configuration (2713 PCBA-M)
Board Size 2.0" x 2.0"
Board Thickness 0.031", Board Material FR-4

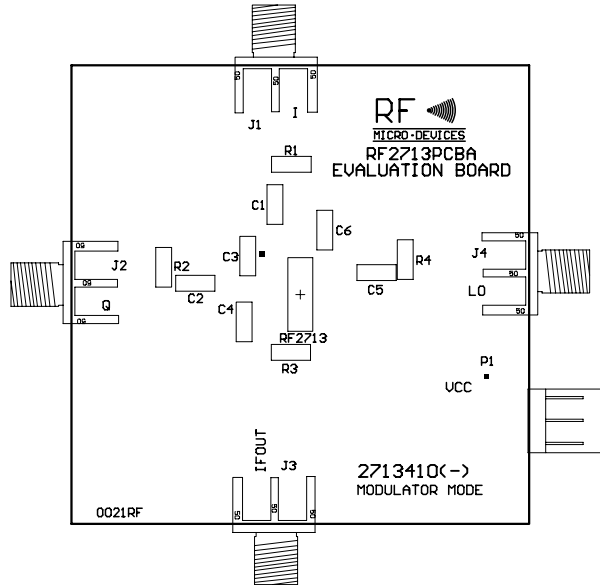

5
MODULATORS AND
UPCONVERTERS

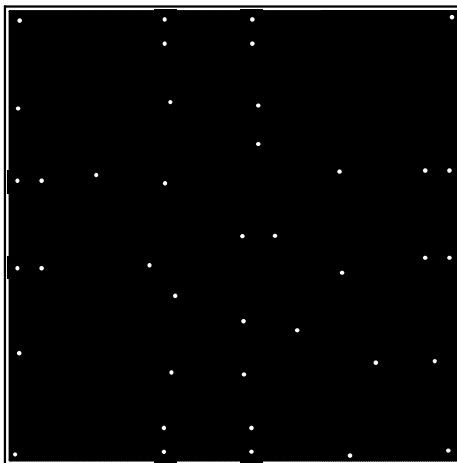
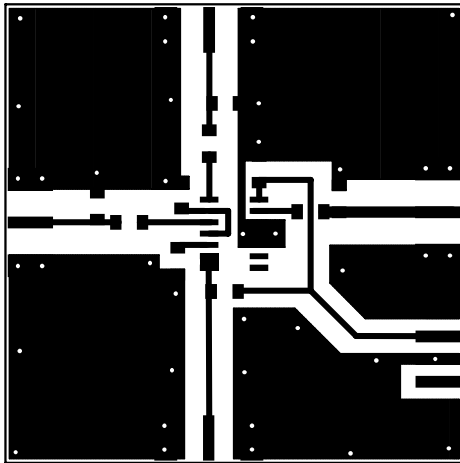

This datasheet has been download from:

www.datasheetcatalog.com

Datasheets for electronics components.