

High-performance Video Signal Switchers

# Single Circuit Video Signal Switcher

## BA7654F, BA7653AF/AFV ,BA7652AF



### •Description

The BA7654F, BA7653AF/AFV, or BA7652AF is a video signal (display signal) switch containing one 2-input or 3-input circuit.

Each of the input pin formats is “sync-tip clamp input” that matches the synchronous tips of video signals (display signals) to the same potential. The inputs have an high input impedance configuration, in which they can utilize a small clamp capacitor (0.01  $\mu$ F (FZ) ceramic capacitor is recommended).

### •Features

- 1) Low value clamp capacitance can be used (Min. 3000 pF Recommended 0.01  $\mu$  F (FZ) ceramic capacitor)
- 2) Low voltage operation is possible (Operating range 4.0~7.0V)
- 3) Superimposed can be applied since switching speed of SW is fast and there is little switching noise (Typ. 70ns)
- 4) Low power consumption (Typ. 25mW when Vcc=5V)
- 5) Large dynamic range (Typ. 3.1V<sub>P-P</sub> when Vcc=5V)
- 6) Good frequency characteristics (Typ. 10 MHz 0 dB)
- 7) Low interchannel crosstalk (Typ. -70 dB)
- 8) Voltage can be applied to the CTL pin without a VCC voltage.
- 9) Built-in mute function (BA7652AF)

### •Applications

VCR, TV, and other applications that use display signals.

### •Product lineup

Part No.	Input type	Mute	Supply voltage(V)
BA7654F	2 in 1 Circuit	—	4.0 ~ 7.0
BA7653AF/AFV	3 in 1 Circuit	—	
BA7652AF	3 in 1 Circuit	○	

● **Absolute maximum ratings** (Ta=25°C)

Parameter	Symbol	Limits				Unit
		BA7654F	BA7653AF	BA7653AFV	BA7652AF	
Supply voltage	V <sub>cc</sub>	9				V
Power dissipation	P <sub>d</sub>	500* <sup>1</sup>	500* <sup>1</sup>	350* <sup>2</sup>	500* <sup>1</sup>	mW
Operating temperature	T <sub>opr</sub>	-25~+75	-30~+80	-30~+80	-30~+80	°C
Storage temperature	T <sub>stg</sub>	-55~+125				°C

\*<sup>1</sup> Reduce by 5.0mW/°C over 25°C, when mounted on a 50mm × 50mm PCB board.(BA7654F, BA7653AF, BA7652AF)

\*<sup>2</sup> Reduce by 3.5mW/°C over 25°C, when mounted on a 50mm × 50mm PCB board.(BA7653AFV)

● **Operating range** (Ta=25°C)

Parameter	Symbol	Limits	Unit
Supply voltage	V <sub>cc</sub>	4.0 ~ 7.0	V

Note: This IC is not designed to be radiation-resistant.

● **Electrical characteristics** (Unless otherwise noted, Ta=25°C, V<sub>cc</sub>=5.0V)

Parameter	Symbol	Min.	Typ.	Max.	Unit	Conditions
Circuit current	I <sub>cc</sub>	2.7	5.0	8.2	mA	
Maximum output level	V <sub>om</sub>	2.6	3.1	—	V <sub>P-P</sub>	f=1kHz, THD=1.0%
Voltage gain	G <sub>v</sub>	-0.5	0	+0.5	dB	f=1MHz, V <sub>IN</sub> =1.0V <sub>P-P</sub>
Inter channel crosstalk	C <sub>ta</sub>	—	-70	—	dB	f=4.43MHz, V <sub>IN</sub> =1.0V <sub>P-P</sub>
Frequency characteristics	C <sub>f</sub>	-3.0	0	+1.0	dB	f=10MHz/1MHz, V <sub>IN</sub> =1.0V <sub>P-P</sub>
CTL switching voltage	V <sub>TH L</sub>	—	—	1.0	V	V <sub>TH</sub> = (V <sub>cc</sub> -0.75) × 0.44
	V <sub>TH H</sub>	2.5	—	—		

● **Guaranteed design parameters** (Unless otherwise noted, Ta=25°C, V<sub>cc</sub>=5.0V)

Parameter	Symbol	Min.	Typ.	Max.	Unit	Conditions
Differential phase	D <sub>G</sub>	—	0	0.5	%	V <sub>IN</sub> =1.0V <sub>P-P</sub> , standard staircase signal
Differential gain	D <sub>P</sub>	—	0.5	1.0	deg	V <sub>IN</sub> =1.0V <sub>P-P</sub> , standard staircase signal

●Block diagram

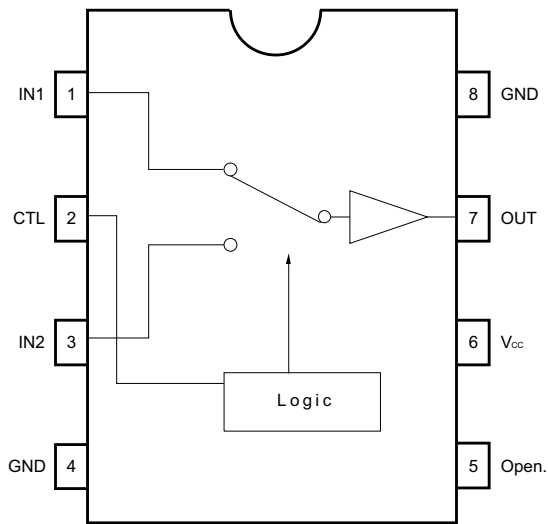

Fig.1 BA7654F

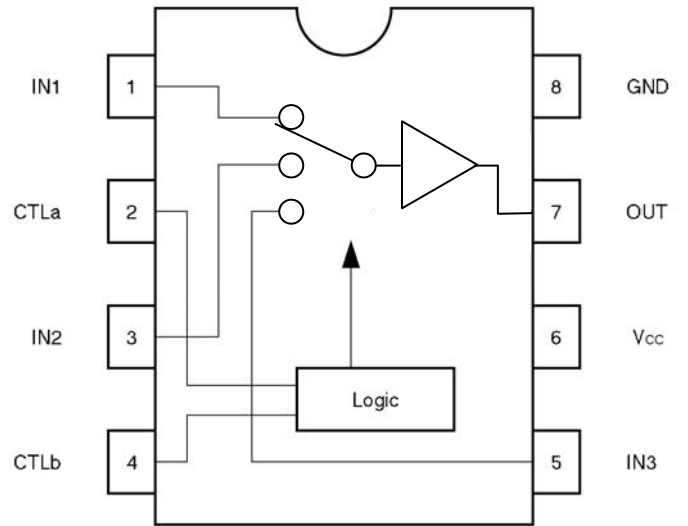

Fig.2 BA7653AF/AFV

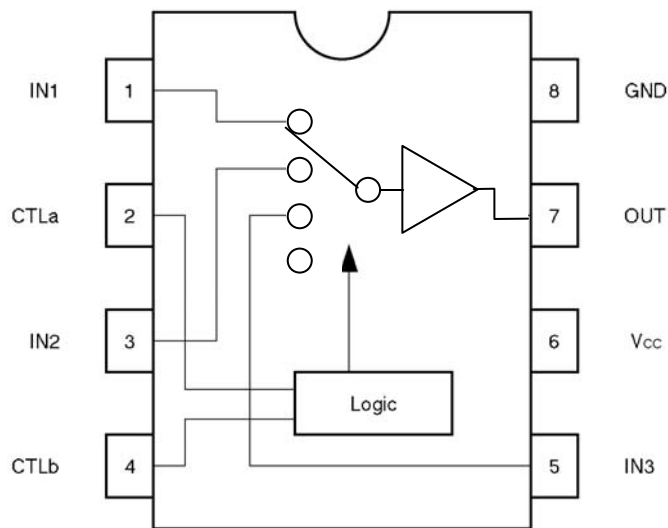

Fig.3 BA7652AF

●Control Pin Settings

BA7654F	
CTL	OUT
L	IN1
H	IN2

BA7653AF/AFV		
CTLa	CTLb	OUT
L	L	IN1
H	L	IN2
L	H	IN3
H	H	IN3

BA7652AF		
CTLa	CTLb	OUT
L	L	IN1
H	L	IN2
L	H	IN3
H	H	MUTE

●Pin descriptions 1/2 (BA7654F)

BA7654F				
Pin No.	Pin name	DC voltage (Vcc=5V)	Input/output impedance	Equivalent circuit
1 (3)	IN1 (IN2)	1.65V	10MΩ or more	
2	CTL	—	—	
4 (8)	GND	0V	—	
5	N.C.	open	open	—
6	Vcc	5V	—	
7	OUT	0.95V	26Ω	

●Pin descriptions 2/2 (BA7653AF/53AFV/52AF)

BA7653AF/53AFV/52AF				
Pin No.	Pin name	DC voltage (Vcc=5V)	Input/output impedance	Equivalent circuit
1 (3) (5)	IN1 (IN2) (IN3)	1.65V	10MΩ or more	
2	CTLa	—	—	
4	CTLb	—	—	
6	Vcc	5.0V	—	
7	OUT	0.95V	26Ω	
8	GND	0V	—	

●Application circuit 1/2 (BA7654F)

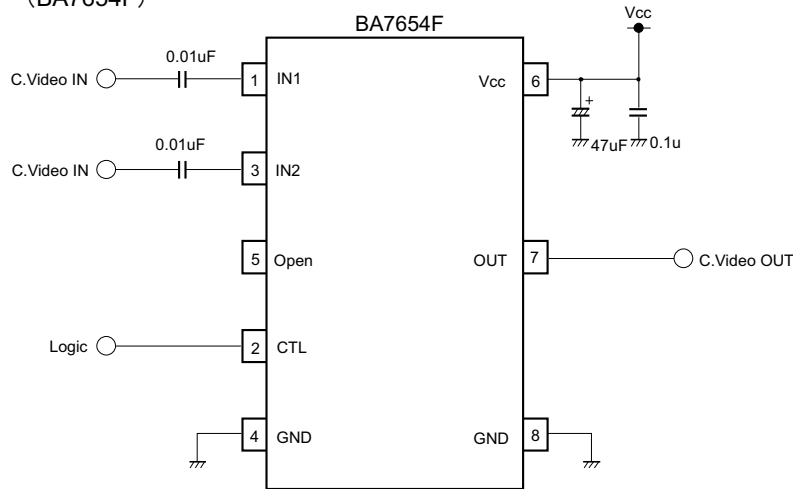

Fig.4

(When superimposition is used)

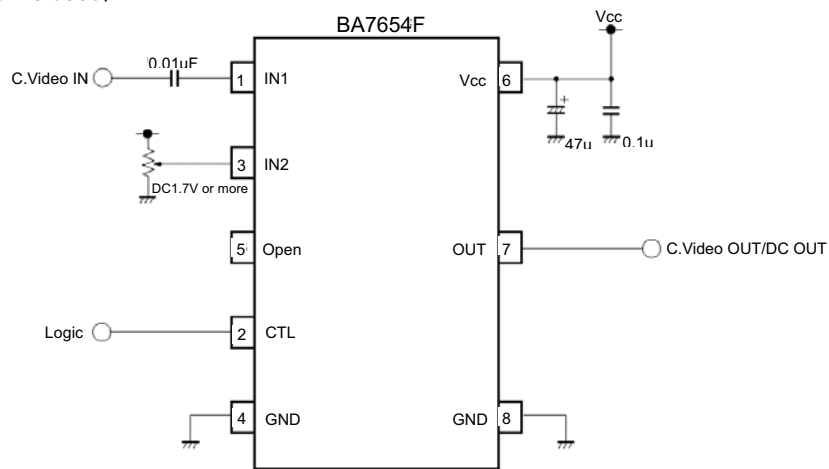

Fig.5

●Cautions on use

1. Numbers and data in entries are representative design values and are not guaranteed values of the items.
2. Although ROHM is confident that the example application circuit reflects the best possible recommendations, be sure to verify circuit characteristics for your particular application. Modification of constants for other externally connected circuits may cause variations in both static and transient characteristics for external components as well as this Rohm IC. Allow for sufficient margins when determining circuit constants.
3. Absolute maximum ratings
 

Use of the IC in excess of absolute maximum ratings, such as the applied voltage or operating temperature range (Topr), may result in IC damage. Assumptions should not be made regarding the state of the IC (short mode or open mode) when such damage is suffered. A physical safety measure, such as a fuse, should be implemented when using the IC at times where the absolute maximum ratings may be exceeded.
4. GND potential
 

Ensure a minimum GND pin potential in all operating conditions. Make sure that no pins are at a voltage below the GND at any time, regardless of whether it is a transient signal or not.
5. Thermal design
 

Perform thermal design, in which there are adequate margins, by taking into account the permissible dissipation (Pd) in actual states of use.
6. Short circuit between terminals and erroneous mounting
 

Pay attention to the assembly direction of the ICs. Wrong mounting direction or shorts between terminals, GND, or other components on the circuits, can damage the IC.
7. Operation in strong electromagnetic field
 

Using the ICs in a strong electromagnetic field can cause operation malfunction.
8. For clamp operation stability
 

Set the output impedance of the stage before a BA7654AF input pin no more than 1 kΩ.

9. An input clamp capacitor will cause delay in operation at power on. Therefore, it is recommended to use a clamp capacitor no larger than  $0.1 \mu\text{F}$  (A  $0.01 \mu\text{F}$  (FZ) ceramic capacitor is recommended).
10. CTL pin is in indeterminate status when left Open. Set it at "H" or "L" level.
11. For superimposed, a 1.7v DC voltage should be applied directly to an input pin.

●Application circuit 2/2 (BA7653AF/53AFV/52AF)

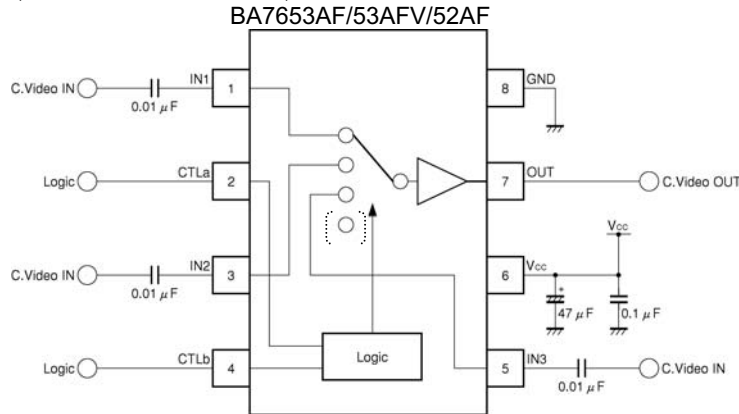

Fig.6

(When superimposition is used)

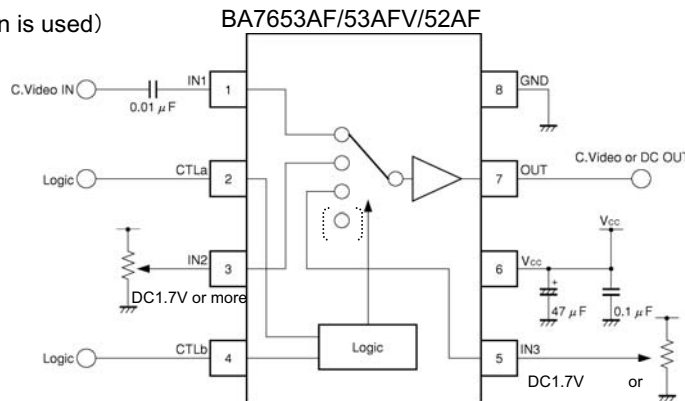

Fig.7

●Cautions on use

1. Numbers and data in entries are representative design values and are not guaranteed values of the items.
2. Although ROHM is confident that the example application circuit reflects the best possible recommendations, be sure to verify circuit characteristics for your particular application. Modification of constants for other externally connected circuits may cause variations in both static and transient characteristics for external components as well as this Rohm IC. Allow for sufficient margins when determining circuit constants.
3. Absolute maximum ratings  
Use of the IC in excess of absolute maximum ratings, such as the applied voltage or operating temperature range ( $T_{opr}$ ), may result in IC damage. Assumptions should not be made regarding the state of the IC (short mode or open mode) when such damage is suffered. A physical safety measure, such as a fuse, should be implemented when using the IC at times where the absolute maximum ratings may be exceeded.
4. GND potential  
Ensure a minimum GND pin potential in all operating conditions. Make sure that no pins are at a voltage below the GND at any time, regardless of whether it is a transient signal or not.
5. Thermal design  
Perform thermal design, in which there are adequate margins, by taking into account the permissible dissipation ( $P_d$ ) in actual states of use.
6. Short circuit between terminals and erroneous mounting  
Pay attention to the assembly direction of the ICs. Wrong mounting direction or shorts between terminals, GND, or other components on the circuits, can damage the IC.
7. Operation in strong electromagnetic field  
Using the ICs in a strong electromagnetic field can cause operation malfunction.
8. For clamp operation stability  
Set the output impedance of the stage before a BA7653AF/53AFV/52AF input pin no more than  $1 \text{ k}\Omega$ .
9. An input clamp capacitor will cause delay in operation at power on. Therefore, it is recommended to use a clamp capacitor no larger than  $0.1 \mu\text{F}$  (A  $0.01 \mu\text{F}$  (FZ) ceramic capacitor is recommended).

10. The BA7653AF/53AFV/52AF is a 3-input, 1-output switch. If it is used as a 2-input, 1-output switch, by leaving one input Open and unused, the Open input pin will oscillate. However, this does not affect other pins and is not particularly a problem for operation. If necessary, connect the input pin to GND via a capacitor or connect the input pin directly to  $V_{CC}$  to stop oscillation.
11. CTL pin is in indeterminate status when left Open. Set it at "H" or "L" level.
12. For superimposed, a 1.7v DC voltage should be applied directly to an input pin.

•Selection of order type

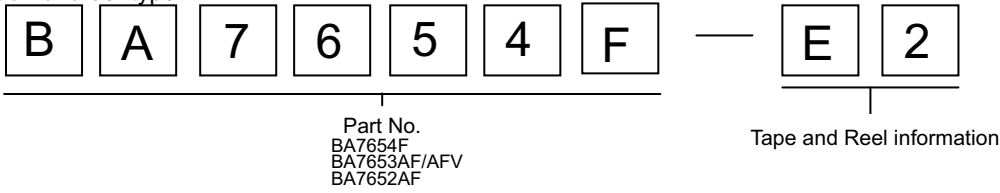

**SOP8**

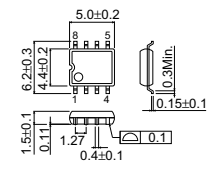
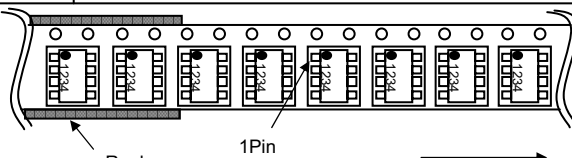
<p>&lt;Dimension&gt;</p>  <p style="text-align: right;">(Unit:mm)</p>	<p>&lt;Tape and Reel information&gt;</p> <table border="1" style="width: 100%; border-collapse: collapse;"> <tr> <td style="width: 15%;">Tape</td> <td>Embossed carrier tape</td> </tr> <tr> <td>Quantity</td> <td>2500pcs</td> </tr> <tr> <td>Direction of feed</td> <td>E2 (The direction is the 1pin of product is at the upper left when you hold reel on the left hand and you pull out the tape on the right hand)</td> </tr> </table>  <p style="text-align: right;">※When you order , please order in times the amount of package quantity.</p>	Tape	Embossed carrier tape	Quantity	2500pcs	Direction of feed	E2 (The direction is the 1pin of product is at the upper left when you hold reel on the left hand and you pull out the tape on the right hand)
Tape	Embossed carrier tape						
Quantity	2500pcs						
Direction of feed	E2 (The direction is the 1pin of product is at the upper left when you hold reel on the left hand and you pull out the tape on the right hand)						

**SSOP-B8**

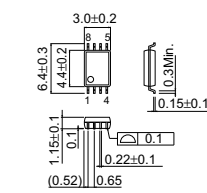
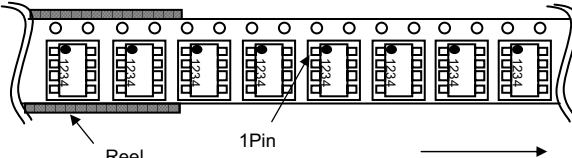
<p>&lt;Dimension&gt;</p> 	<p>&lt;Tape and Reel information&gt;</p> <table border="1" style="width: 100%; border-collapse: collapse;"> <tr> <td style="width: 15%;">Tape</td> <td>Embossed carrier tape</td> </tr> <tr> <td>Quantity</td> <td>2500pcs</td> </tr> <tr> <td>Direction of feed</td> <td>E2 (The direction is the 1pin of product is at the upper left when you hold reel on the left hand and you pull out the tape on the right hand)</td> </tr> </table>  <p style="text-align: right;">※When you order , please order in times the amount of package quantity.</p>	Tape	Embossed carrier tape	Quantity	2500pcs	Direction of feed	E2 (The direction is the 1pin of product is at the upper left when you hold reel on the left hand and you pull out the tape on the right hand)
Tape	Embossed carrier tape						
Quantity	2500pcs						
Direction of feed	E2 (The direction is the 1pin of product is at the upper left when you hold reel on the left hand and you pull out the tape on the right hand)						



- The contents described herein are correct as of August, 2008
- The contents described herein are subject to change without notice. For updates of the latest information, please contact and confirm with ROHM CO.,LTD.
- Any part of this application note must not be duplicated or copied without our permission.
- Application circuit diagrams and circuit constants contained herein are shown as examples of standard use and operation. Please pay careful attention to the peripheral conditions when designing circuits and deciding upon circuit constants in the set.
- Any data, including, but not limited to application circuit diagrams and information, described herein are intended only as illustrations of such devices and not as the specifications for such devices. ROHM CO.,LTD. disclaims any warranty that any use of such devices shall be free from infringement of any third party's intellectual property rights or other proprietary rights, and further, assumes no liability of whatsoever nature in the event of any such infringement, or arising from or connected with or related to the use of such devices.
- Upon the sale of any such devices, other than for buyer's right to use such devices itself, resell or otherwise dispose of the same, implied right or license to practice or commercially exploit any intellectual property rights or other proprietary rights owned or controlled by ROHM CO., LTD. is granted to any such buyer.
- The products described herein utilize silicon as the main material.
- The products described herein are not designed to be X ray proof.

The products listed in this catalog are designed to be used with ordinary electronic equipment or devices (such as audio visual equipment, office-automation equipment, communications devices, electrical appliances and electronic toys). Should you intend to use these products with equipment or devices which require an extremely high level of reliability and the malfunction of which would directly endanger human life (such as medical instruments, transportation equipment, aerospace machinery, nuclear-reactor controllers, fuel controllers and other safety devices), please be sure to consult with our sales representative in advance.

Contact us for further information about the products.

<b>San Diego</b>	TEL: +1-858-625-3630	FAX: +1-858-625-3670	<b>Tianjin</b>	TEL: +86-22-23029181	FAX: +86-22-23029183
<b>Atlanta</b>	TEL: +1-770-754-5972	FAX: +1-770-754-0691	<b>Shanghai</b>	TEL: +86-21-6279-2727	FAX: +86-21-6247-2066
<b>Boston</b>	TEL: +1-978-371-0382	FAX: +1-928-438-7164	<b>Hangzhou</b>	TEL: +86-571-87658072	FAX: +86-571-87658071
<b>Chicago</b>	TEL: +1-847-368-1006	FAX: +1-847-368-1008	<b>Nanjing</b>	TEL: +86-25-8689-0015	FAX: +86-25-8689-0393
<b>Dallas</b>	TEL: +1-469-287-5366	FAX: +1-469-362-7973	<b>Ningbo</b>	TEL: +86-574-87654201	FAX: +86-574-87654208
<b>Denver</b>	TEL: +1-303-708-0908	FAX: +1-303-708-0858	<b>Qingdao</b>	TEL: +86-532-5779-312	FAX: +86-532-5779-653
<b>Detroit</b>	TEL: +1-248-348-9920	FAX: +1-248-348-9942	<b>Suzhou</b>	TEL: +86-510-82702693	FAX: +86-510-82702992
<b>Nashville</b>	TEL: +1-615-620-6700	FAX: +1-615-620-6702	<b>Wuxi</b>	TEL: +86-510-82702693	FAX: +86-510-82702992
<b>Mexico</b>	TEL: +52-33-3123-2001	FAX: +52-33-3123-2002	<b>Shenzhen</b>	TEL: +86-755-8307-3008	FAX: +86-755-8307-3003
<b>Düsseldorf</b>	TEL: +49-2154-9210	FAX: +49-2154-921400	<b>Dongguan</b>	TEL: +86-769-8393-3320	FAX: +86-769-8398-4140
<b>Munich</b>	TEL: +49-8999-216168	FAX: +49-8999-216176	<b>Fuzhou</b>	TEL: +86-591-8801-8698	FAX: +86-591-8801-8690
<b>Stuttgart</b>	TEL: +49-711-7272-370	FAX: +49-711-7272-3720	<b>Guangzhou</b>	TEL: +86-20-3878-8100	FAX: +86-20-3825-5965
<b>France</b>	TEL: +33-1-5697-3060	FAX: +33-1-5697-3080	<b>Huizhou</b>	TEL: +86-752-205-1054	FAX: +86-752-205-1059
<b>United Kingdom</b>	TEL: +44-1-908-306700	FAX: +44-1-908-235788	<b>Xiamen</b>	TEL: +86-592-238-5705	FAX: +86-592-239-8380
<b>Denmark</b>	TEL: +45-3694-4739	FAX: +45-3694-4789	<b>Zhuhai</b>	TEL: +86-756-3232-480	FAX: +86-756-3232-460
<b>Espoo</b>	TEL: +358-9725-54491	FAX: +358-9-7255-4499	<b>Hong Kong</b>	TEL: +852-2-740-6262	FAX: +852-2-375-8971
<b>Salo</b>	TEL: +358-2-7332234	FAX: +358-2-7332237	<b>Taipei</b>	TEL: +886-2-2500-6956	FAX: +886-2-2503-2869
<b>Oulu</b>	TEL: +358-8-5372930	FAX: +358-8-5372931	<b>Kaohsiung</b>	TEL: +886-7-237-0881	FAX: +886-7-238-7332
<b>Barcelona</b>	TEL: +34-9375-24320	FAX: +34-9375-24410	<b>Singapore</b>	TEL: +65-6332-2322	FAX: +65-6332-5662
<b>Hungary</b>	TEL: +36-1-4719338	FAX: +36-1-4719339	<b>Philippines</b>	TEL: +63-2-807-6872	FAX: +63-2-809-1422
<b>Poland</b>	TEL: +48-22-5757213	FAX: +48-22-5757001	<b>Thailand</b>	TEL: +66-2-254-4890	FAX: +66-2-256-6334
<b>Russia</b>	TEL: +7-495-739-41-74	FAX: +7-495-739-41-74	<b>Kuala Lumpur</b>	TEL: +60-3-7958-8355	FAX: +60-3-7958-8377
<b>Seoul</b>	TEL: +82-2-8182-700	FAX: +82-2-8182-715	<b>Penang</b>	TEL: +60-4-2286453	FAX: +60-4-2286452
<b>Masan</b>	TEL: +82-55-240-6234	FAX: +82-55-240-6236	<b>Kyoto</b>	TEL: +81-75-365-1218	FAX: +81-75-365-1228
<b>Dalian</b>	TEL: +86-411-8230-8549	FAX: +86-411-8230-8537	<b>Yokohama</b>	TEL: +81-45-476-2290	FAX: +81-45-476-2295
<b>Beijing</b>	TEL: +86-10-8525-2483	FAX: +86-10-8525-2489			

Excellence in Electronics

**ROHM**

**ROHM CO., LTD.**

21 Saiin Mizosaki-cho, Ukyo-ku, Kyoto  
615-8585, Japan  
TEL: +81-75-311-2121 FAX: +81-75-315-0172  
URL: <http://www.rohm.com>

Published by  
KTC LSI Development Headquarters  
LSI Business Promotion Group

### Notes

- No technical content pages of this document may be reproduced in any form or transmitted by any means without prior permission of ROHM CO.,LTD.
- The contents described herein are subject to change without notice. The specifications for the product described in this document are for reference only. Upon actual use, therefore, please request that specifications to be separately delivered.
- Application circuit diagrams and circuit constants contained herein are shown as examples of standard use and operation. Please pay careful attention to the peripheral conditions when designing circuits and deciding upon circuit constants in the set.
- Any data, including, but not limited to application circuit diagrams information, described herein are intended only as illustrations of such devices and not as the specifications for such devices. ROHM CO.,LTD. disclaims any warranty that any use of such devices shall be free from infringement of any third party's intellectual property rights or other proprietary rights, and further, assumes no liability of whatsoever nature in the event of any such infringement, or arising from or connected with or related to the use of such devices.
- Upon the sale of any such devices, other than for buyer's right to use such devices itself, resell or otherwise dispose of the same, no express or implied right or license to practice or commercially exploit any intellectual property rights or other proprietary rights owned or controlled by
- ROHM CO., LTD. is granted to any such buyer.
- Products listed in this document are no antiradiation design.

The products listed in this document are designed to be used with ordinary electronic equipment or devices (such as audio visual equipment, office-automation equipment, communications devices, electrical appliances and electronic toys).

Should you intend to use these products with equipment or devices which require an extremely high level of reliability and the malfunction of which would directly endanger human life (such as medical instruments, transportation equipment, aerospace machinery, nuclear-reactor controllers, fuel controllers and other safety devices), please be sure to consult with our sales representative in advance.

It is our top priority to supply products with the utmost quality and reliability. However, there is always a chance of failure due to unexpected factors. Therefore, please take into account the derating characteristics and allow for sufficient safety features, such as extra margin, anti-flammability, and fail-safe measures when designing in order to prevent possible accidents that may result in bodily harm or fire caused by component failure. ROHM cannot be held responsible for any damages arising from the use of the products under conditions out of the range of the specifications or due to non-compliance with the NOTES specified in this catalog.

Thank you for your accessing to ROHM product informations.

More detail product informations and catalogs are available, please contact your nearest sales office.

**ROHM** Customer Support System

THE AMERICAS / EUROPE / ASIA / JAPAN

[www.rohm.com](http://www.rohm.com)

Contact us : [webmaster@rohm.co.jp](mailto:webmaster@rohm.co.jp)