



## TDA2822

## LINEAR INTEGRATED CIRCUIT

### DUAL LOW VOLTAGE POWER AMPLIFIER

#### DESCRIPTION

The UTC TDA2822 is a monolithic integrated audio amplifier in a 8-Pin plastic dual in line package. It is designed for portable cassette players and radios.

#### FEATURES

- \* Wide Operating Supply Voltage:  $V_{CC}=1.8V - 12V$ .
- \* Low Crossover Distortion.
- \* Low Quiescent Circuit Current.
- \* Bridge/Stereo Configuration.

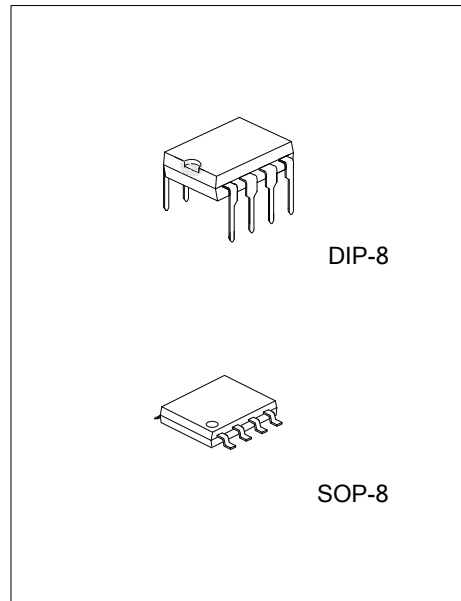

#### ORDERING INFORMATION

Ordering Number		Package	Packing
Lead Free	Halogen Free		
TDA2822L-D08-T	TDA2822G-D08-T	DIP-8	Tube
TDA2822L-S08-R	TDA2822G-S08-R	SOP-8	Tape Reel

<p>TDA2822G-D08-T</p> <p>(1)Packing Type</p> <p>(2)Package Type</p> <p>(3)Green Package</p>	<p>(1) T: Tube, R: Tape Reel</p> <p>(2) D08: DIP-8, S08: SOP-8</p> <p>(3) G: Halogen Free and Lead Free, L: Lead Free</p>
---	---

#### MARKING

DIP-8	SOP-8
<p>8 7 6 5 → Date Code</p> <p>UTC □ □ □ □</p> <p>TDA2822 □</p> <p>□ □ → L: Lead Free</p> <p>□ □ → G: Halogen Free</p> <p>□ □ → Lot Code</p> <p>1 2 3 4</p>	<p>8 7 6 5 → Date Code</p> <p>UTC □ □ □ □</p> <p>TDA2822 □</p> <p>□ □ → L: Lead Free</p> <p>□ □ → G: Halogen Free</p> <p>□ □ → Lot Code</p> <p>1 2 3 4</p>

## ■ PIN CONFIGURATIONS

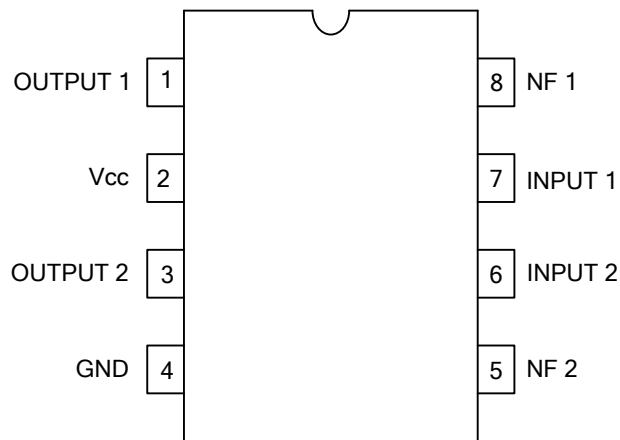

## ■ BLOCK DIAGRAM

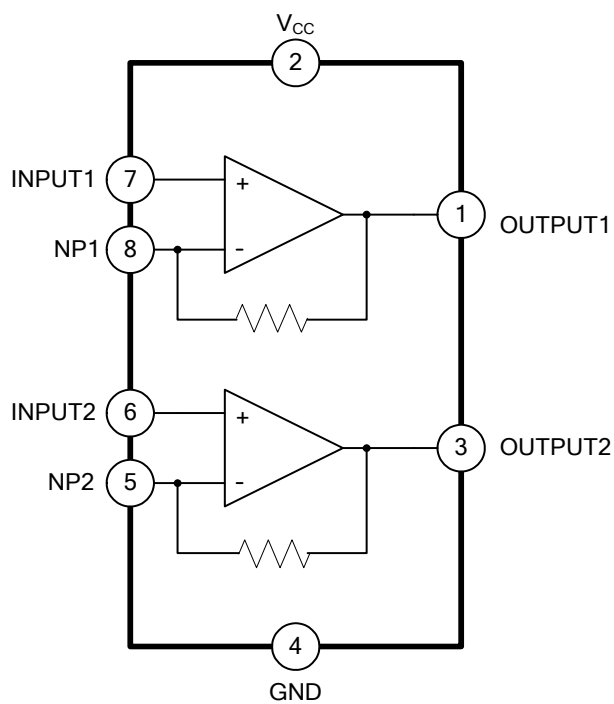

### ■ ABSOLUTE MAXIMUM RATINGS (T<sub>A</sub>=25°C, unless otherwise specified)

PARAMETER	SYMBOL	RATINGS	UNIT
Supply Voltage	V <sub>CC</sub>	15	V
Output Peak Current	I <sub>O(PEAK)</sub>	1	A
Power Dissipation	DIP-8	1.0	W
	SOP-8	0.5	
Operating Temperature	T <sub>OPR</sub>	-20~+85	°C
Storage Temperature	T <sub>STG</sub>	-40~+150	°C

Note:1. Absolute maximum ratings are stress ratings only and functional device operation is not implied. The device could be damaged beyond Absolute maximum ratings.

2. The device is guaranteed to meet performance specifications within 0°C~70°C operating temperature range and assured by design from -20°C~85°C

### ■ ELECTRICAL CHARACTERISTICS (T<sub>A</sub>=25°C, V<sub>CC</sub>=6V, f=1kHz, unless otherwise specified)

PARAMETER	SYMBOL	TEST CONDITIONS	MIN	TYP	MAX	UNIT
Operating Supply Voltage	V <sub>CC</sub>		1.8		12	V
Quiescent Circuit Current	I <sub>CC</sub>	V <sub>IN</sub> =0		9		mA
Closed Loop Voltage Gain	G <sub>Vc</sub>	Stereo		40		dB
			Bridge		40	
Channel Balance	CB	Stereo	-1	0	1	dB
Output Power(Stereo)	DIP-8	V <sub>CC</sub> =6V, R <sub>L</sub> =4Ω, THD=10%	0.4	0.65		W
	SOP-8		0.28	0.45		
	DIP-8	V <sub>CC</sub> =3V, R <sub>L</sub> =4Ω, THD=10%		0.11		W
	SOP-8			0.07		
Output Power (Bridge)	DIP-8	V <sub>CC</sub> =6V, R <sub>L</sub> =4Ω, THD=10%	0.9	1.35		W
	SOP-8		0.63	0.94		
	DIP-8	V <sub>CC</sub> =3V, R <sub>L</sub> =4Ω, THD=10%		0.35		W
	SOP-8			0.24		
Total Harmonic Distortion	THD	R <sub>L</sub> =8Ω, P <sub>OUT</sub> =0.2W		0.5		%
		R <sub>L</sub> =8Ω, P <sub>OUT</sub> =0.5W		0.5		%
Ripple Rejection	RR	Stereo, f=100Hz, C3=100μF	24	30		dB
Output Noise Voltage	eN	Stereo, BW(-3dB)=20Hz ~20kHz		0.5	2.0	mV
Cross Talk	C <sub>T</sub>	Stereo, f=1kHz		50		dB
Input Resistance	R <sub>IN</sub>		100			kΩ

## ■ TEST CIRCUIT

### STEREO

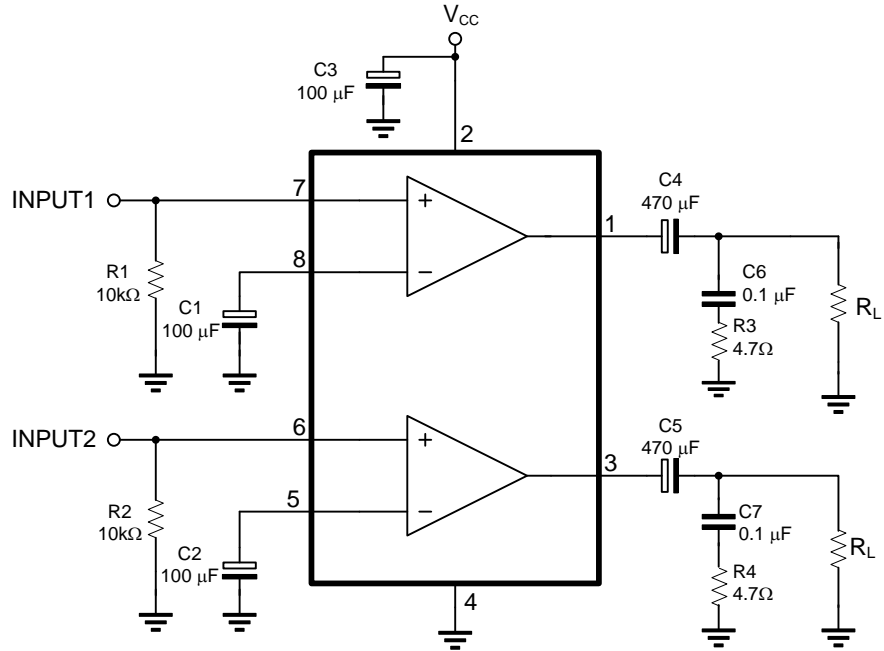

### BRIDGE

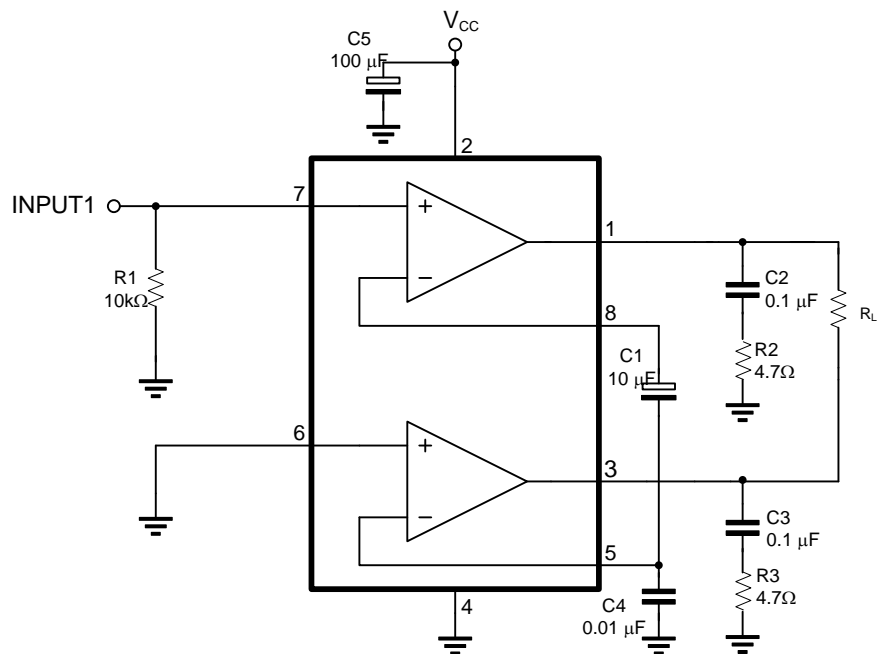

## ■ SCHEMATIC DIAGRAM

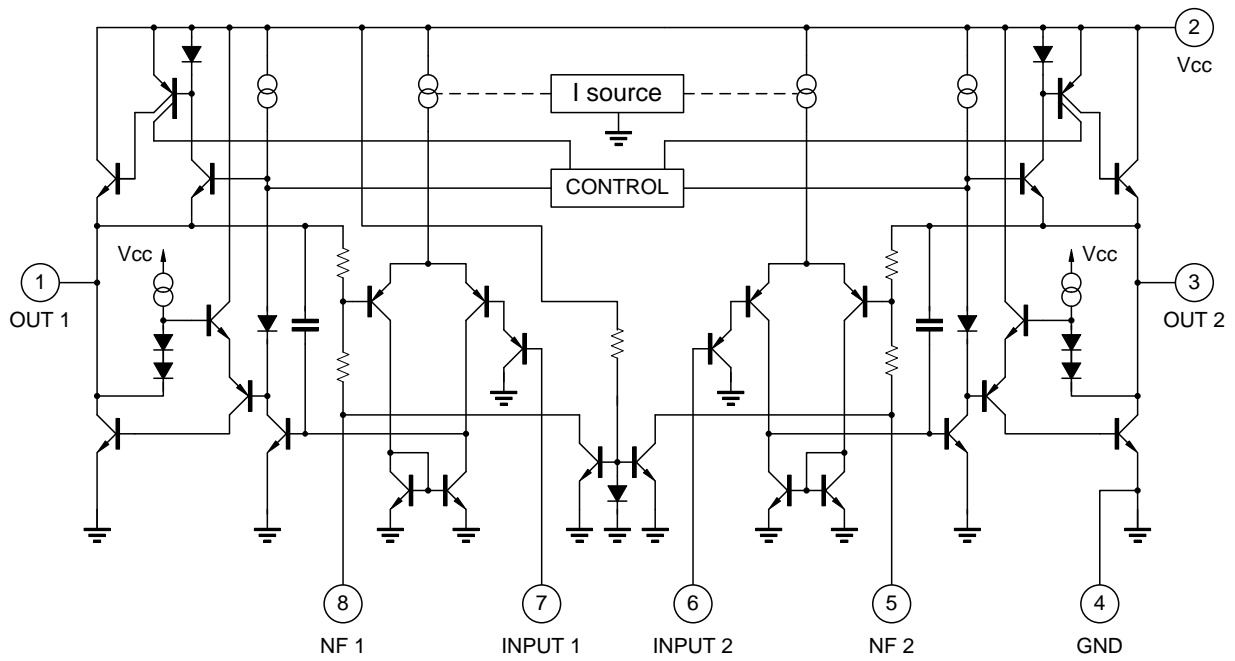

### ■ TYPICAL CHARACTERISTICS

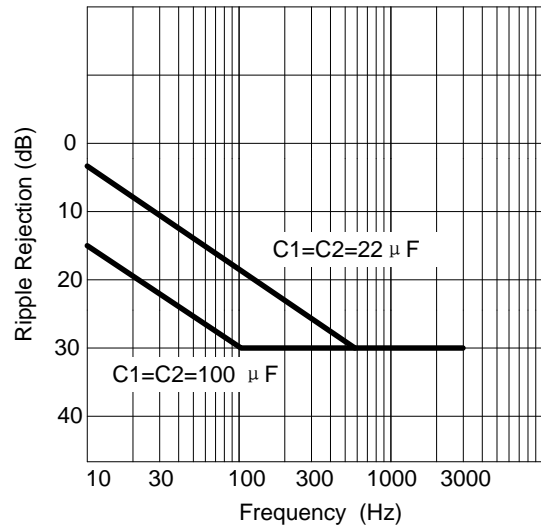
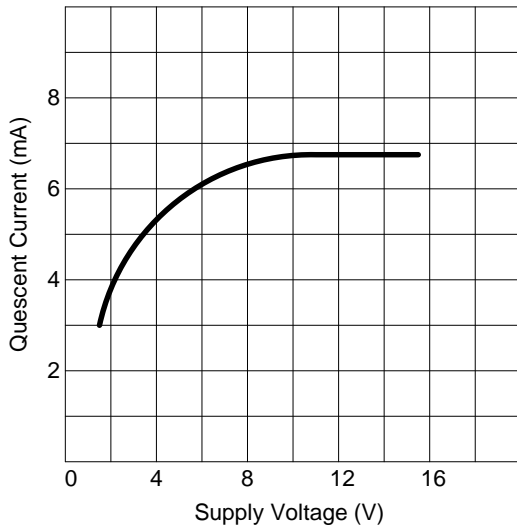

UTC assumes no responsibility for equipment failures that result from using products at values that exceed, even momentarily, rated values (such as maximum ratings, operating condition ranges, or other parameters) listed in products specifications of any and all UTC products described or contained herein. UTC products are not designed for use in life support appliances, devices or systems where malfunction of these products can be reasonably expected to result in personal injury. Reproduction in whole or in part is prohibited without the prior written consent of the copyright owner. UTC reserves the right to make changes to information published in this document, including without limitation specifications and product descriptions, at any time and without notice. This document supersedes and replaces all information supplied prior to the publication hereof.