

**PCM56P**  
**PCM56U**

DESIGNED FOR AUDIO

## Serial Input 16-Bit Monolithic DIGITAL-TO-ANALOG CONVERTER

### FEATURES

- SERIAL INPUT
- -92dB MAX THD: FS Input, K Grade
- -74dB MAX THD: -20dB Input, K Grade
- 96dB DYNAMIC RANGE
- NO EXTERNAL COMPONENTS REQUIRED
- 16-BIT RESOLUTION
- 15-BIT MONOTONICITY, TYP
- 0.001% OF FSR TYP DIFFERENTIAL LINEARITY ERROR
- 1.5 $\mu$ s SETTling TIME, TYP: Voltage Out
- $\pm$ 3V OR  $\pm$ 1mA AUDIO OUTPUT
- EIAJ STC-007-COMPATIBLE
- OPERATES ON  $\pm$ 5V TO  $\pm$ 12V SUPPLIES
- PINOUT ALLOWS I<sub>OUT</sub> OPTION
- PLASTIC DIP OR SOIC PACKAGE

### DESCRIPTION

The PCM56 is a state-of-the-art, fully monotonic, digital-to-analog converter that is designed and specified for digital audio applications. This device employs ultra-stable nichrome (NiCr) thin-film resistors to provide monotonicity, low distortion, and low differential linearity error (especially around bipolar zero) over long periods of time and over the full operating temperature.

This converter is completely self-contained with a stable, low noise, internal zener voltage reference; high speed current switches; a resistor ladder network; and a fast settling, low noise output operational amplifier all on a single monolithic chip. The converters are operated using two power supplies that can range from  $\pm$ 5V to  $\pm$ 12V. Power dissipation with  $\pm$ 5V supplies is typically less than 200mW. Also included is a provision for external adjustment of the MSB error (differential linearity error at bipolar zero) to further improve total harmonic distortion (THD) specifications if desired. Few external components are necessary for operation, and all critical specifications are 100% tested. This helps assure the user of high system reliability and outstanding overall system performance.

The PCM56 is packaged in a high-quality 16-pin molded plastic DIP package or SOIC and has passed operating life tests under simultaneous high-pressure, high-temperature, and high-humidity conditions.

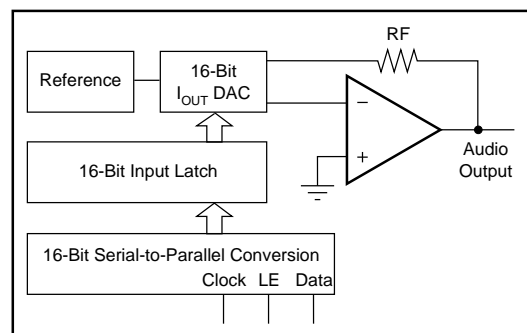

# SPECIFICATIONS

## ELECTRICAL

Typical at +25°C, and nominal power supply voltages ±5V, unless otherwise noted.

PARAMETER	PCM56U, PCM56P-J, -K			UNITS
	MIN	TYP	MAX	
<b>DIGITAL INPUT</b>				
Resolution		16		Bits
Digital Inputs <sup>(1)</sup> : $V_{IH}$	+2.4		+ $V_L$	V
$V_{IL}$	0		+0.8	V
$I_{IH}, V_{IN} = +2.7V$			+1.0	μA
$I_{IL}, V_{IN} = +0.4V$			-50	μA
Input Clock Frequency	10.0			MHz
<b>TRANSFER CHARACTERISTICS</b>				
<b>ACCURACY</b>				
Gain Error		±2.0		%
Bipolar Zero Error		±30		mV
Differential Linearity Error		±0.001		% of FSR <sup>(2)</sup>
Noise (rms, 20Hz to 20kHz) at Bipolar Zero ( $V_{OUT}$ models)		6		μV
<b>TOTAL HARMONIC DISTORTION</b>				
$V_O = \pm FS$ at $f = 991Hz$ : PCM56P-K		-94	-92	dB
PCM56P-J		-94	-88	dB
PCM56P, PCM56U		-94	-82	dB
PCM56P-L		-94	-80	dB
$V_O = -20dB$ at $f = 991Hz$ : PCM56P-K		-75	-74	dB
PCM56P-J		-75	-68	dB
PCM56P, PCM56U		-75	-68	dB
PCM56P-L		-75	-60	dB
$V_O = -60dB$ at $f = 991Hz$ : PCM56P-K		-35	-34	dB
PCM56P-J		-35	-28	dB
PCM56P, PCM56U		-35	-28	dB
PCM56P-L		-35	-20	dB
<b>MONOTONICITY</b>		15		Bits
<b>DRIFT</b> (0°C to +70°C)				
Total Drift <sup>(3)</sup>		±25		ppm of FSR/°C
Bipolar Zero Drift		±4		ppm of FSR/°C
<b>SETTLING TIME</b> (to ±0.006% of FSR)				
Voltage Output: 6V Step		1.5		μs
1LSB		1.0		μs
Slew Rate		10		V/μs
Current Output, 1mA Step: 10Ω to 100Ω Load		350		ns
1kΩ Load <sup>(4)</sup>		350		ns
<b>WARM-UP TIME</b>	1			Min
<b>OUTPUT</b>				
Voltage Output Configuration: Bipolar Range		±3.0		V
Output Current	±2.0			mA
Output Impedance		0.10		Ω
Short Circuit Duration				
Current Output Configuration:		Indefinite to Common		
Bipolar Range (±30%)		±1.0		mA
Output Impedance (±30%)		1.2		kΩ
<b>POWER SUPPLY REQUIREMENTS<sup>(5)</sup></b>				
Voltage: + $V_S$ and + $V_L$	+4.75	+5.00	+13.2	V
- $V_S$ and - $V_L$	-4.75	-5.00	-13.2	V
Supply Drain (No Load): +V (+ $V_S$ and + $V_L = +5V$ )		+10.00	+17.0	mA
-V (- $V_S$ and - $V_L = -5V$ )		-25.0	-35.0	mA
+V (+ $V_S$ and + $V_L = +12V$ )		+12.0		mA
-V (- $V_S$ and - $V_L = -12V$ )		-27.0		mA
Power Dissipation: $V_S$ and $V_L = \pm 5V$		175	260	mW
$V_S$ and $V_L = \pm 12V$		468		mW
<b>TEMPERATURE RANGE</b>				
Specification	0		+70	°C
Operation	-25		+70	°C
Storage	-60		+100	°C

NOTES: (1) Logic input levels are TTL/CMOS-compatible. (2) FSR means full-scale range and is equivalent to 6V (±3V) for PCM56 in the  $V_{OUT}$  mode. (3) This is the combined drift error due to gain, offset, and linearity over temperature. (4) Measured with an active clamp to provide a low impedance for approximately 200ns. (5) All specifications assume + $V_S$  connected to + $V_L$  and - $V_S$  connected to - $V_L$ . If supplies are connected separately, - $V_L$  must not be more negative than - $V_S$  supply voltage to assure proper operation. No similar restriction applies to the value of + $V_L$  with respect to + $V_S$ .

## ABSOLUTE MAXIMUM RATINGS

DC Supply Voltages .....	$\pm 16\text{VDC}$
Input Logic Voltage .....	$-1\text{V to } +V_S/+V_L$
Power Dissipation .....	850mW
Operating Temperature .....	$-25^\circ\text{C to } +70^\circ\text{C}$
Storage Temperature .....	$-60^\circ\text{C to } +100^\circ\text{C}$
Lead Temperature (soldering, 10s) .....	$+300^\circ\text{C}$

## PACKAGE INFORMATION

MODEL	PACKAGE	PACKAGE DRAWING NUMBER <sup>(1)</sup>
PCM56U	16-Pin SOIC	211
PCM56P	16-Pin Plastic DIP	180
PCM56P-J	16-Pin Plastic DIP	180
PCM56P-K	16-Pin Plastic DIP	180
PCM56P-L	16-Pin Plastic DIP	180

NOTE: (1) For detailed drawing and dimension table, please see end of data sheet, or Appendix D of Burr-Brown IC Data Book.

## PIN ASSIGNMENTS

PIN	DESCRIPTION	MNEMONIC
P1	Analog Negative Supply	$-V_S$
P2	Logic Common	LOG COM
P3	Logic Positive Supply	$+V_L$
P4	No Connection	NC
P5	Clock Input	CLK
P6	Latch Enable Input	LE
P7	Serial Data Input	DATA
P8	Logic Negative Supply	$-V_L$
P9	Voltage Output	$V_{OUT}$
P10	Feedback Resistor	RF
P11	Summing Junction	SJ
P12	Analog Common	ANA COM
P13	Current Output	$I_{OUT}$
P14	MSB Adjustment Terminal	MSB ADJ
P15	MSB Trim-pot Terminal	TRIM
P16	Analog Positive Supply	$+V_S$

## CONNECTION DIAGRAM

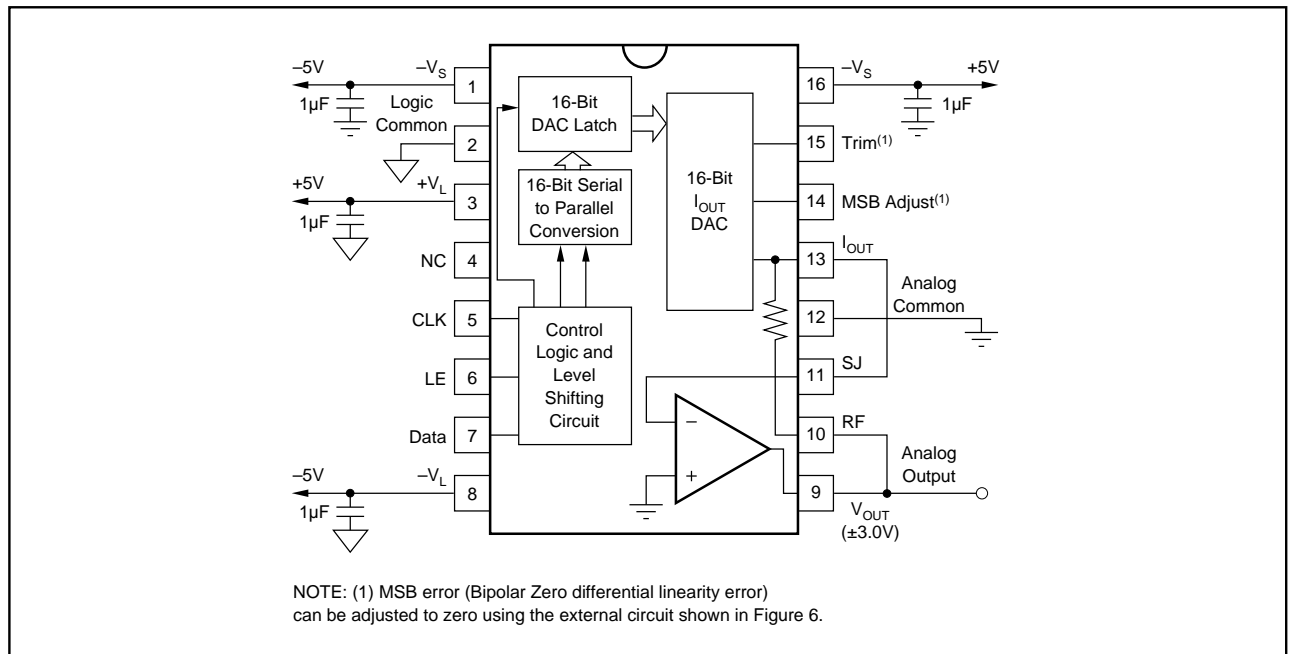

# DISCUSSION OF SPECIFICATIONS

The PCM56 is specified to provide critical performance criteria for a wide variety of applications. The most critical specifications for D/A converter in audio applications are Total Harmonic Distortion, Differential Linearity Error, Bipolar Zero Error, parameter shifts with time and temperature, and settling time effects on accuracy.

The PCM56 is factory-trimmed and tested for all critical key specifications.

The accuracy of a D/A converter is described by the transfer function shown in Figure 1. Digital input to analog output relationship is shown in Table I. The errors in the D/A converter are combinations of analog errors due to the linear circuitry, matching and tracking properties of the ladder and scaling networks, power supply rejection, and reference errors. In summary, these errors consist of initial errors including Gain, Offset, Linearity, Differential Linearity, and Power Supply Sensitivity. Gain drift over temperature rotates the line (Figure 1) about the bipolar zero point and Offset drift shifts the line left or right over the operating temperature range. Most of the Offset and Gain drift with temperature or time is due to the drift of the internal reference zener diode. The converter is designed so that these drifts are in opposite directions. This way the Bipolar Zero voltage is virtually unaffected by variations in the reference voltage.

## DIGITAL INPUT CODES

The PCM56 accepts serial input data (MSB first) in the Binary Two's Complement (BTC) form. Refer to Table I for input/output relationships.

DIGITAL INPUT	ANALOG OUTPUT		
	DAC Output	Voltage (V), V <sub>OUT</sub> Mode	Current (mA), I <sub>OUT</sub> Mode
7FFF Hex	+ Full Scale	+2.999908	-0.999970
8000 Hex	- Full Scale	-3.000000	+1.000000
0000 Hex	Bipolar Zero	0.000000	0.000000
FFFF Hex	Zero -1LSB	-0.000092	+0.030500µA

TABLE I. Digital Input to Analog Output Relationship.

## BIPOLAR ZERO ERROR

Initial Bipolar Zero Error (Bit 1 “on” and all other bits “off”) is the deviation from 0V out and is factory-trimmed to typically ±30mV at +25°C.

## DIFFERENTIAL LINEARITY ERROR

Differential Linearity Error (DLE) is the deviation from an ideal 1LSB change from one adjacent output state to the next. DLE is important in audio applications because excessive DLE at Bipolar Zero (at the “major carry”) can result in audible crossover distortion for low level output signals. Initial DLE on the PCM56 is factory trimmed to typically ±0.001% of FSR. The MSB DLE is adjustable to zero using the circuit shown in Figure 6.

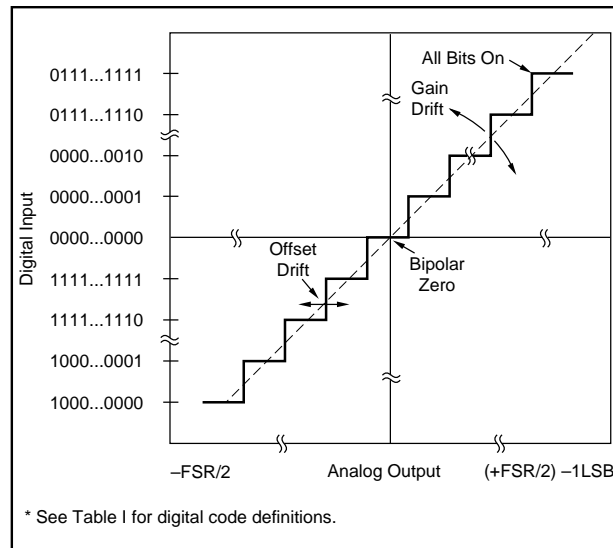

FIGURE 1. Input vs Output for an Ideal Bipolar D/A Converter.

## POWER SUPPLY SENSITIVITY

Changes in the DC power supplies will affect accuracy. The PCM56 power supply sensitivity is shown by Figure 2. Normally, regulated power supplies with 1% or less ripple are recommended for use with the DAC. See also Power Supply Connections paragraph in the Installation and Operating Instructions section.

## SETTLING TIME

Settling time is the total time (including slew time) required for the output to settle within an error band around its final value after a change in input (see Figure 3).

Settling times are specified to ±0.006% of FSR: one for a large output voltage change of 6V and one for a 1LSB change. The 1LSB change is measured at the major carry (0000 hex to ffff hex), the point at which the worst-case settling time occurs.

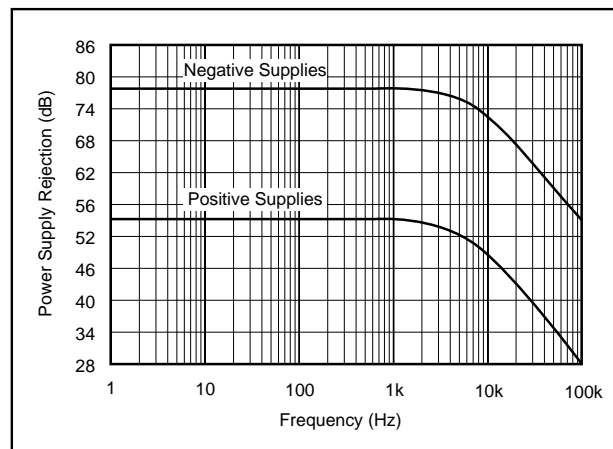

FIGURE 2. Power Supply Sensitivity.

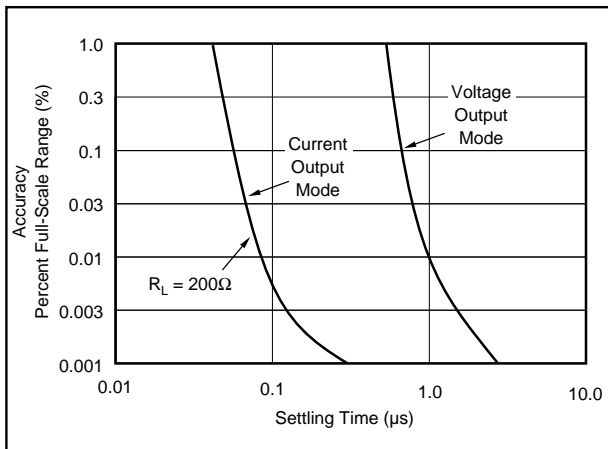

FIGURE 3. Full Scale Range Settling Time vs Accuracy.

### STABILITY WITH TIME AND TEMPERATURE

The parameters of a D/A converter designed for audio applications should be stable over a relatively wide temperature range and over long periods of time to avoid undesirable periodic readjustment. The most important parameters are Bipolar Zero Error, Differential Linearity Error, and Total Harmonic Distortion. Most of the Offset and Gain drift with temperature or time is due to the drift of the internal reference zener diode. The PCM56 is designed so that these drifts are in opposite directions so that the Bipolar Zero voltage is virtually unaffected by variations in the reference voltage. Both DLE and THD are dependent upon the matching and tracking of resistor ratios and upon  $V_{BE}$  and  $h_{FE}$  of the current-source transistors. The PCM56 was designed so that any absolute shift in these components has virtually no effect on DLE or THD. The resistors are made of identical links of ultra-stable nichrome thin-film. The current density in these resistors is very low to further enhance their stability.

### DYNAMIC RANGE

The Dynamic Range is a measure of the ratio of the smallest signals the converter can produce to the full-scale range and is usually expressed in decibels (dB). The theoretical dynamic range of a converter is approximately  $6 \times n$ , or about 96dB of a 16-bit converter. The actual, or useful, dynamic range is limited by noise and linearity errors and is therefore somewhat less than the theoretical limit. However, this does point out that a resolution of at least 16 bits is required to obtain a 90dB minimum dynamic range, regardless of the accuracy of the converter. Another specification that is useful for audio applications is Total Harmonic Distortion.

### TOTAL HARMONIC DISTORTION

THD is useful in audio applications and is a measure of the magnitude and distribution of the Linearity Error, Differential Linearity Error, and Noise, as well as Quantization Error. To be useful, THD should be specified for both high level and low level input signals. This error is unadjustable and is the most meaningful indicator of D/A converter accuracy for audio applications.

The THD is defined as the ratio of the square root of the sum of the squares of the values of the harmonics to the value of the fundamental input frequency and is expressed in percent or dB. The rms value of the PCM56 error referred to the input can be shown to be:

$$\epsilon_{rms} = \sqrt{\frac{1}{n} \sum_{i=1}^n [E_L(i) + E_Q(i)]^2} \quad (1)$$

where  $n$  is the number of samples in one cycle of any given sine wave,  $E_L(i)$  is the linearity error of the PCM56 at each sampling point, and  $E_Q(i)$  is the quantization error at each sampling point. The THD can then be expressed as:

$$\begin{aligned} \text{THD} &= \epsilon_{rms} / E_{rms} \\ &= \frac{\sqrt{\frac{1}{n} \sum_{i=1}^n [E_L(i) + E_Q(i)]^2}}{E_{rms}} \times 100\% \end{aligned} \quad (2)$$

where  $E_{rms}$  is the rms signal-voltage level.

This expression indicates that, in general, there is a correlation between the THD and the square root of the sum of the squares of the linearity errors at each digital word of interest. However, this expression does not mean that the worst-case linearity error of the D/A is directly correlated to the THD.

For the PCM56 the test period was chosen to be 22.7μs (44.1kHz), which is compatible with the EIAJ STC-007 specification for PCM audio. The test frequency is 991Hz and the amplitude of the input signal is 0dB, -20dB, and -60dB down from full scale.

Figure 4 shows the typical THD as a function of output voltage.

Figure 5 shows typical THD as a function of frequency.

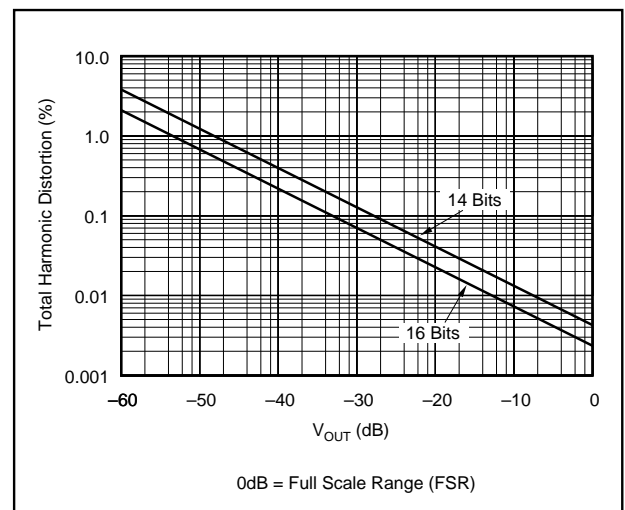

FIGURE 4. Total Harmonic Distortion (THD) vs  $V_{OUT}$ .

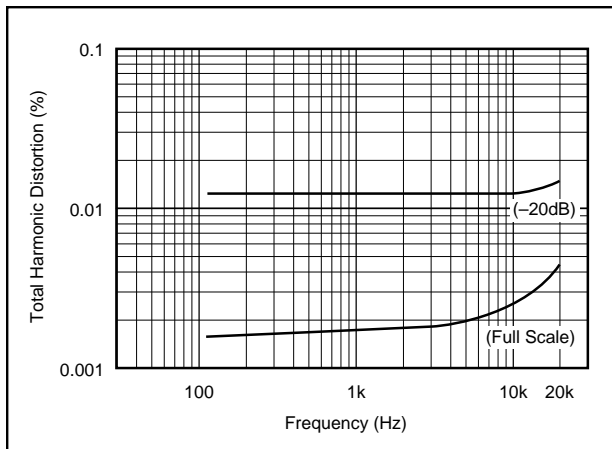

FIGURE 5. Total Harmonic Distortion (THD) vs Frequency.

## INSTALLATION AND OPERATING INSTRUCTIONS

### POWER SUPPLY CONNECTIONS

For optimum performance and noise rejection, power supply decoupling capacitors should be added as shown in the Connection Diagram. These capacitors (1 $\mu$ F tantalum or electrolytic recommended) should be located close to the converter.

### MSB ERROR ADJUSTMENT PROCEDURE (OPTIONAL)

The MSB error of the PCM56 can be adjusted to make the differential linearity error (DLE) at BPZ essentially zero. This is important when the signal output levels are very low, because zero crossing noise (DLE at BPZ) becomes very significant when compared to the small code changes occurring in the LSB portion of the converter.

Differential linearity error at bipolar zero and THD are guaranteed to meet data sheet specifications without any external adjustment. However, a provision has been made for an optional adjustment of the MSB linearity point which makes it possible to eliminate DLE error at BPZ. Two procedures are given to allow either static or dynamic adjustment. The dynamic procedure is preferred because of the difficulty associated with the static method (accurately measuring 16-bit LSB steps).

To statically adjust DLE at BPZ, refer to the circuit shown in Figure 6, or the PCM56 connection diagram.

After allowing ample warm-up time (5-10 minutes) to assure stable operation of the PCM56, select input code FFFF hexadecimal (all bits on except the MSB). Measure the audio output voltage using a 6-1/2 digit voltmeter and record it. Change the digital input code to 0000 hexadecimal (all bits off except the MSB). Adjust the 100k $\Omega$  potentiometer to make the audio output read 92 $\mu$ V more than the voltage reading of the previous code (a 1LSB step = 92 $\mu$ V).

A much simpler method is to dynamically adjust the DLE at BPZ. Again, refer to Figure 6 for circuitry and component values. Assuming the device has been installed in a digital audio application circuit, send the appropriate digital input to produce a -80dB level sinusoidal output. While measuring the THD of the audio circuit output, adjust the 100k $\Omega$  potentiometer until a minimum level of distortion is observed.

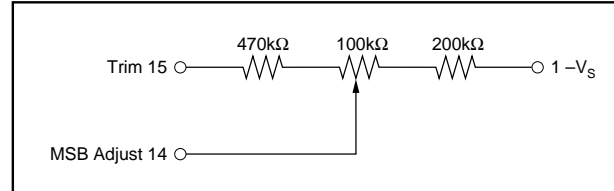

FIGURE 6. MSB Adjustment Circuit.

### INPUT TIMING CONSIDERATIONS

Figure 7 and 8 refer to the input timing required to interface the inputs of PCM56 to a serial input data stream. Serial data is accepted in Binary Two's Complement (BTC) with the MSB being loaded first. Data is clocked in on positive going clock (CLK) edges and is latched into the DAC input register on negative going latch enable (LE) edges.

The latch enable input must be high for at least one clock cycle before going low, and then must be held low for at least one clock cycle. The last 16 data bits clocked into the serial input register are the ones that are transferred to the DAC input register when latch enable goes low. In other words, when more than 16 clock cycles occur between a latch enable, only the data present during the last 16 clocks will be transferred to the DAC input register.

One requirement for clocking in all 16 bits is the necessity for a "17th" clock pulse. This automatically occurs when the clock is continuous (last bit shifts in on the first bit of the next data word). If the clock is stopped between input of 16-bit data words, the latch enable (LE) must remain low until after the first clock of the next 16-bit data word stream. This ensures that the latch is properly set up.

Figure 7 refers to the general input format required for the PCM56. Figure 8 shows the specific relationships between the various signals and their timing constraints.

## INSTALLATION CONSIDERATIONS

If the optional external MSB error circuitry is used, a potentiometer with adequate resolution and a TCR of 100ppm/ $^{\circ}$ C or less is required. Also, extra care must be taken to insure that no leakage path (either AC or DC) exists to pin 14. If the circuit is not used, pins 14 and 15 should be left open.

The PCM converter and the wiring to its connectors should be located to provide the optimum isolation from sources of RFI and EMI. The important consideration in the elimination

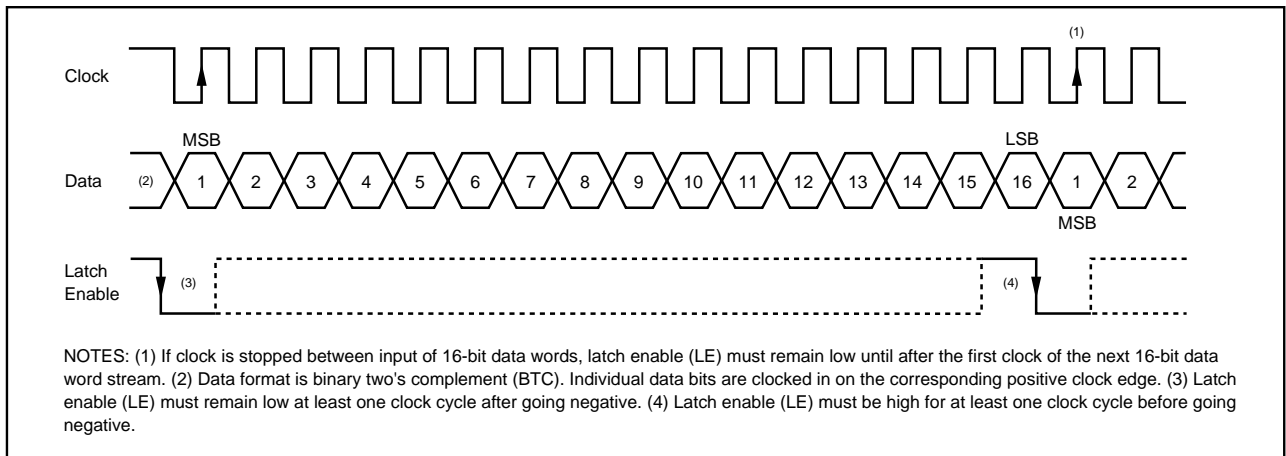

FIGURE 7. Input Timing Diagram.

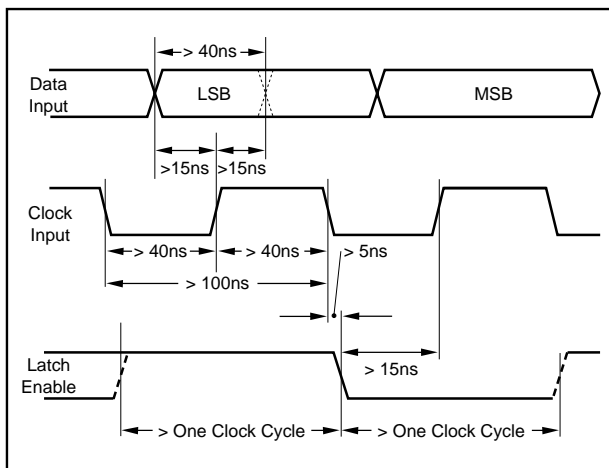

FIGURE 8. Input Timing Relationships.

of RF radiation or pickup is loop area; therefore, signal leads and their return conductors should be kept close together. This reduces the external magnetic field along with any radiation. Also, if a signal lead and its return conductor are wired close together, they represent a small flux-capture cross section for any external field. This reduces radiation pickup in the circuit.

## APPLICATIONS

Figures 9 and 10 show a circuit and timing diagram for a single PCM56 used to obtain both left- and right-channel output in a typical digital audio system. The audio output of the PCM56 is alternately time-shared between the left and right channels. The design is greatly simplified because the PCM56 is a complete D/A converter requiring no external reference or output op amp.

A sample/hold (S/H) amplifier, or “deglitcher” is required at the output of the D/A for both the left and right channel, as shown in Figure 9. The S/H amplifier for the left channel is composed of  $A_1$ ,  $SW_1$ , and associated circuitry.  $A_1$  is used as an integrator to hold the analog voltage in  $C_1$ . Since the

source and drain of the FET switch operate at a virtual ground when “C” and “B” are connected in the sample mode, there is no increase in distortion caused by the modulation effect of  $R_{ON}$  by the audio signal.

Figure 10 shows the deglitcher controls for both left and right channels which are produced by timing control logic. A delay of  $1.5\mu s$  ( $t\omega$ ) is provided to allow the output of the PCM56 to settle within a small error band around its final value before connecting it to the channel output. Due to the fast settling time of the PCM56 it is possible to minimize the delay between the left- and right-channel outputs when using a single D/A converter for both channels. This is important because the right- and left-channel data are recorded in-phase and the use of the slower D/A converter would result in significant phase error at higher frequencies.

The obvious solution to the phase shift problem in a two-channel system would be to use two D/A converters (one per channel) and time the outputs to change simultaneously. Figure 11 shows a block diagram of the final test circuitry used for PCM56. It should be noted that no deglitching circuitry is required on the DAC output to meet specified THD performance. This means that when one PCM56 is used per channel, the need for all the sample/hold and controls circuitry associated with a single DAC (two-channel) design is effectively eliminated. The PCM56 is tested to meet its THD specifications without the need for output deglitching.

A low-pass filter is required after the PCM56 to remove all unwanted frequency components caused by the sampling frequency as well as those resulting from the discrete nature of the D/A output. This filter must have a flat frequency response over the entire audio band (0-20kHz) and a very high attenuation above 20kHz.

Most previous digital audio circuits used a higher order (9-13 pole) analog filter. However, the phase response of an analog filter with these amplitude characteristics is nonlinear and can disturb the pulse-shaped characteristic transients contained in music.

## SECOND GENERATION SYSTEMS

One method of avoiding the problems associated with a higher order analog filter would be to use digital filter oversampling techniques. Oversampling by a factor of two would move the sampling frequency (88.2kHz) out to a point where only a simple low-order phase-linear analog filter is required after the deglitcher output to remove unwanted intermodulation products. In a digital compact disc application, various VLSI chips perform the functions of error detection/correction, digital filtering, and formatting of the digital information to provide the clock, latch enable, and serial input to the PCM56. These VLSI chips are

available from several sources (Sony, Yamaha, Signetics, etc.) and are specifically optimized for digital audio applications.

Oversampled circuitry requires a very fast D/A converter since the sampling frequency is multiplied by a factor of two or more (for each output channel). A single PCM56 can provide two-channel oversampling at a 4X rate (176.4kHz/channel) and still remain well within the settling time requirements for maintaining specified THD performance. This would reduce the complexities of the analog filter even further from that used in 2X oversampling circuitry.

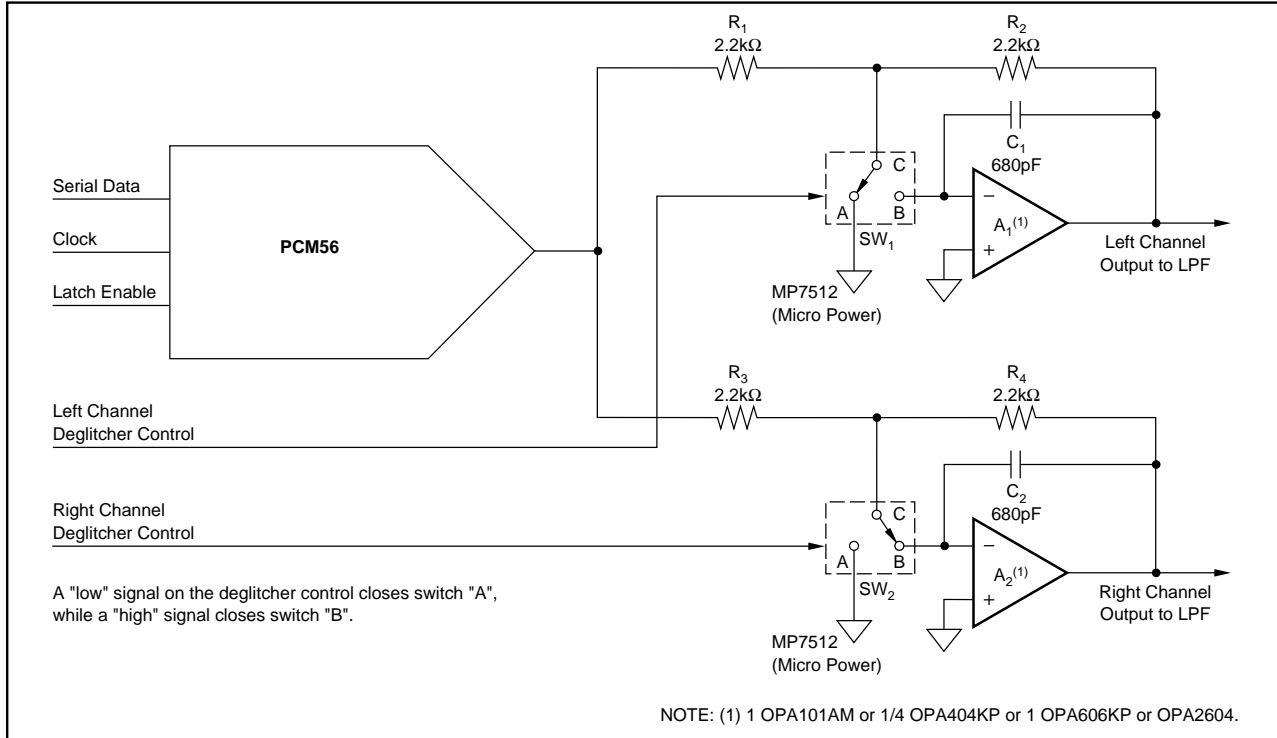

FIGURE 9. A Sample/Hold Amplifier (Deglitcher) is Required at the Digital-to-Analog Output for Both Left and Right Channels.

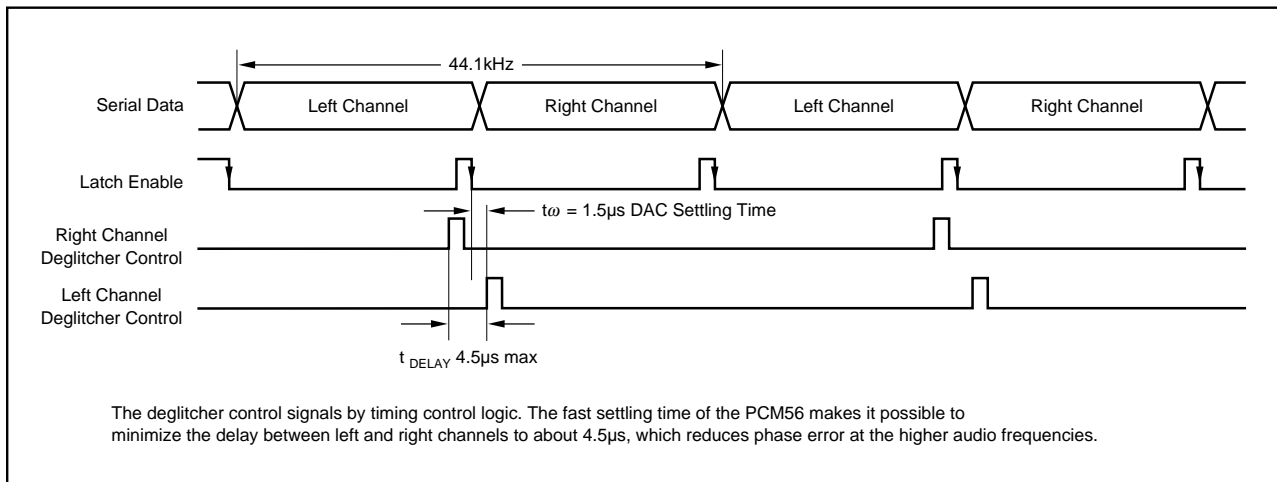

FIGURE 10. Timing Diagram for the Deglitcher Control Signals.



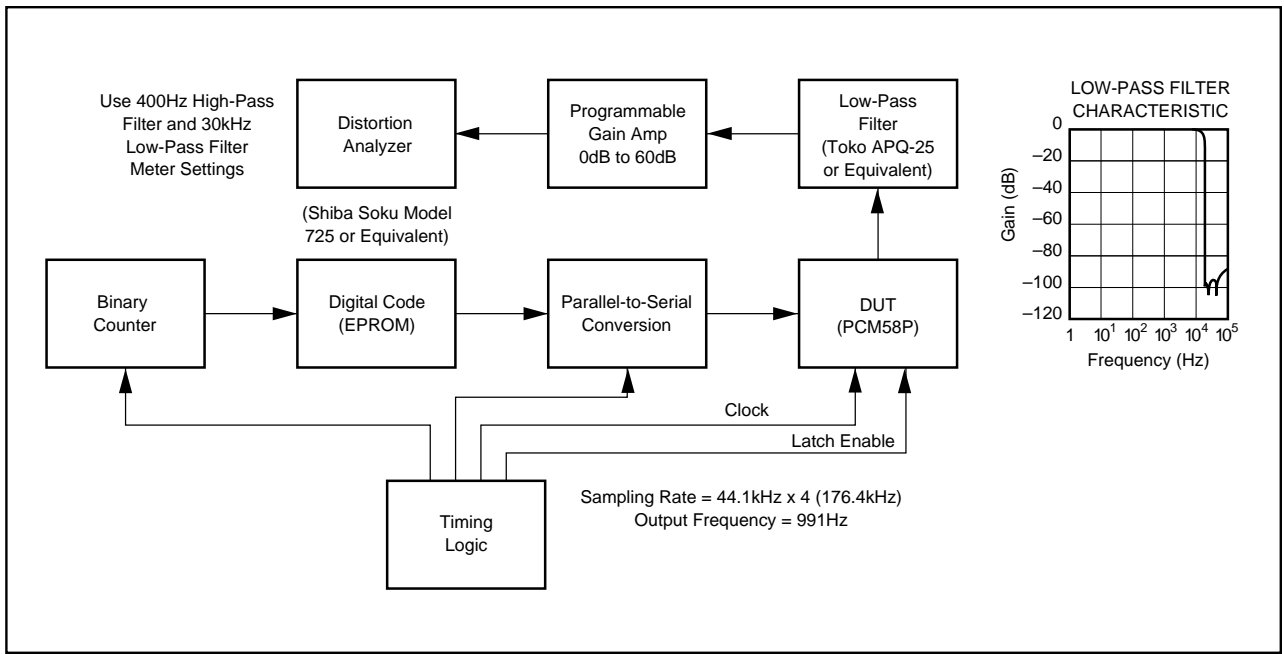

FIGURE 11. Block Diagram of Distortion Test Circuit.

The information provided herein is believed to be reliable; however, BURR-BROWN assumes no responsibility for inaccuracies or omissions. BURR-BROWN assumes no responsibility for the use of this information, and all use of such information shall be entirely at the user's own risk. Prices and specifications are subject to change without notice. No patent rights or licenses to any of the circuits described herein are implied or granted to any third party. BURR-BROWN does not authorize or warrant any BURR-BROWN product for use in life support devices and/or systems.